



America's Ride to Space

CubeSat Express

The Future of Rideshare Launch

April 2017



CubeSat Deployment Video

AV-58

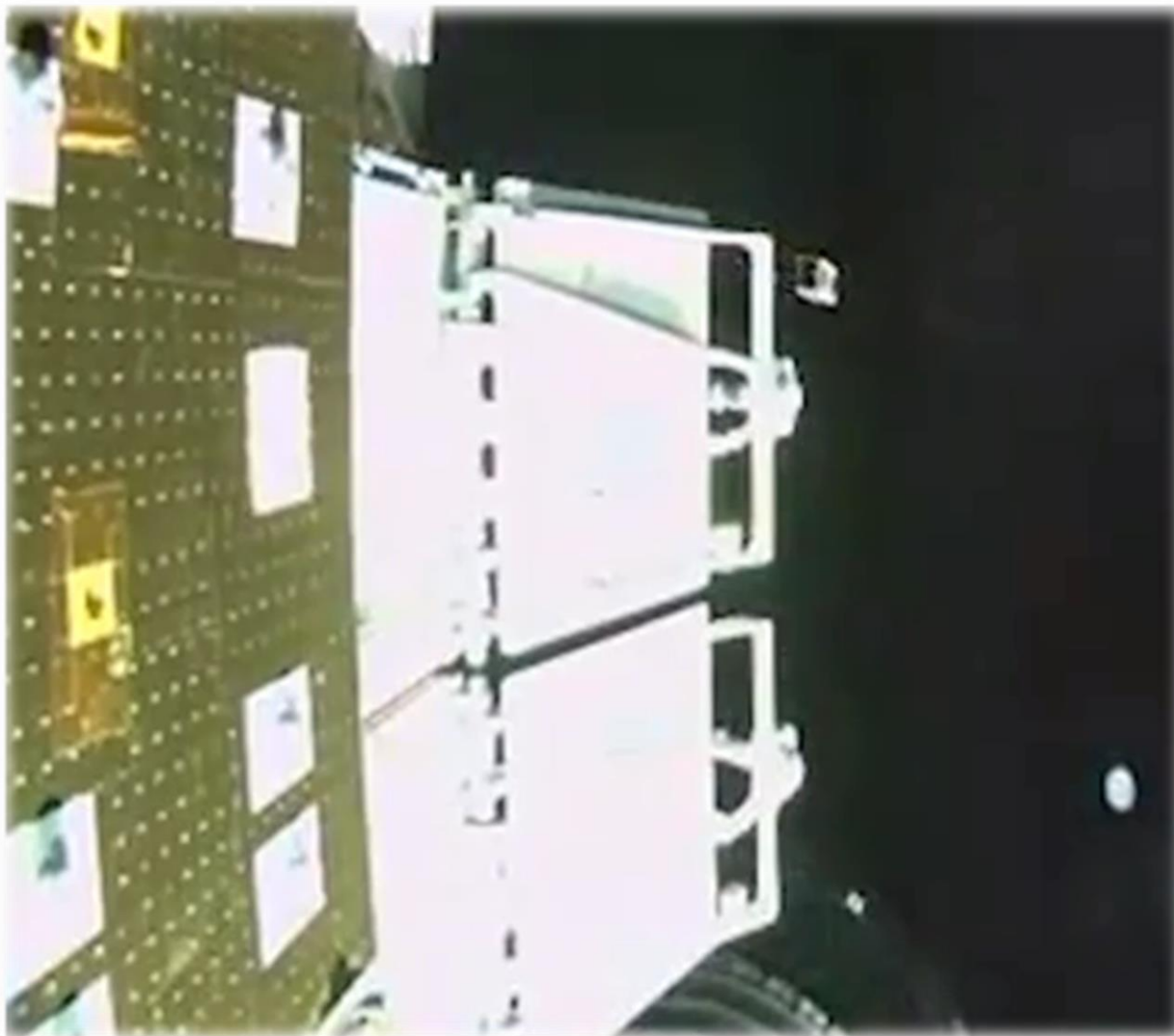

CubeSat Express Vision

- ❑ CubeSat Rideshare on Every Atlas (Single Engine Centaur) and Vulcan Upper Stages
- ❑ Maximizing Launch Vehicle Capability and Mass to Orbit
- ❑ Providing On-Schedule, Reliable, Low Cost Access to Space

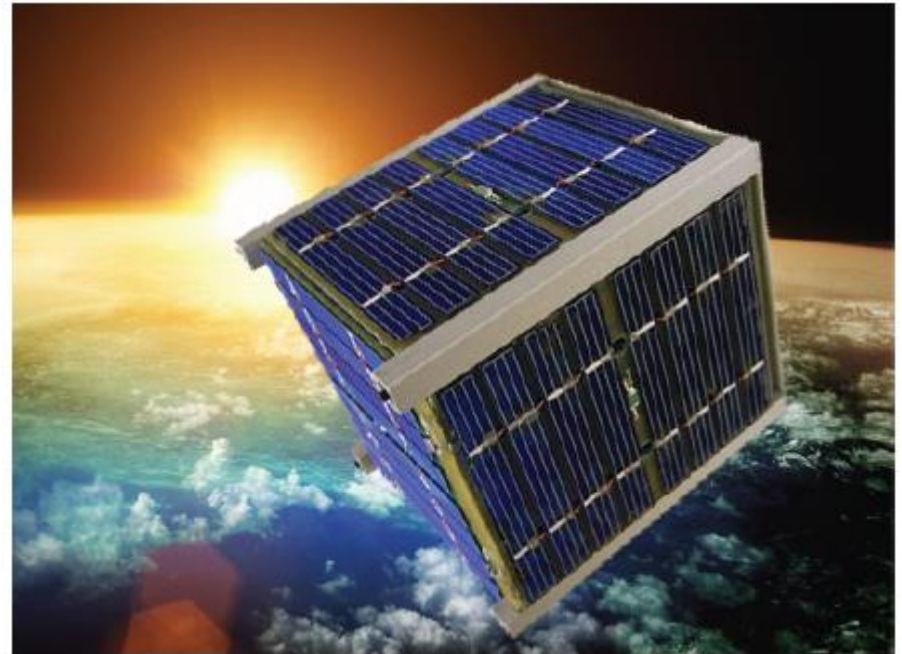

Changing the Paradigm for CubeSat Launch

Aft Bulkhead Carrier (ABC)

Aft Bulkhead Carrier (ABC)	
Description	An interface located at the aft-end of the Atlas V Centaur second-stage
Vehicle	Atlas V, Vulcan Centaur
Capacity	1 ABC per LV
Interface	15-in Bolted Interface
Mass	80 kg (176 lb)
Volume	51 cm x 51 cm x 86 cm (20 in x 20 in x 34 in)
Status	Operational; first launch 09-2012 on NROL-36 (OUTSat - NPSCuL box with 8 P-PODs)

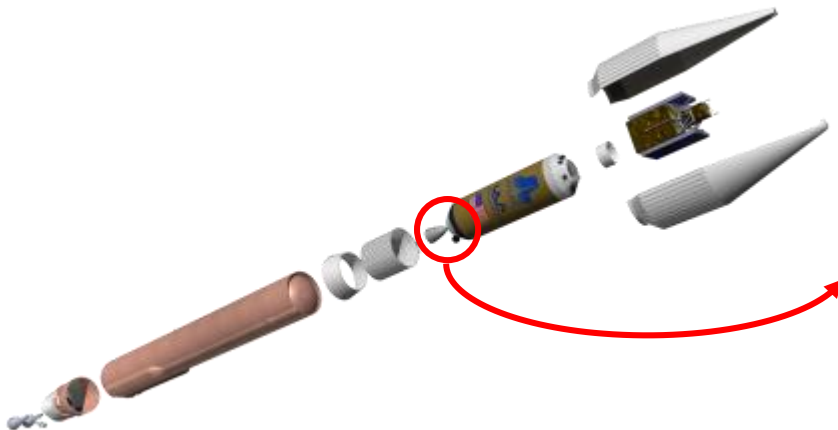
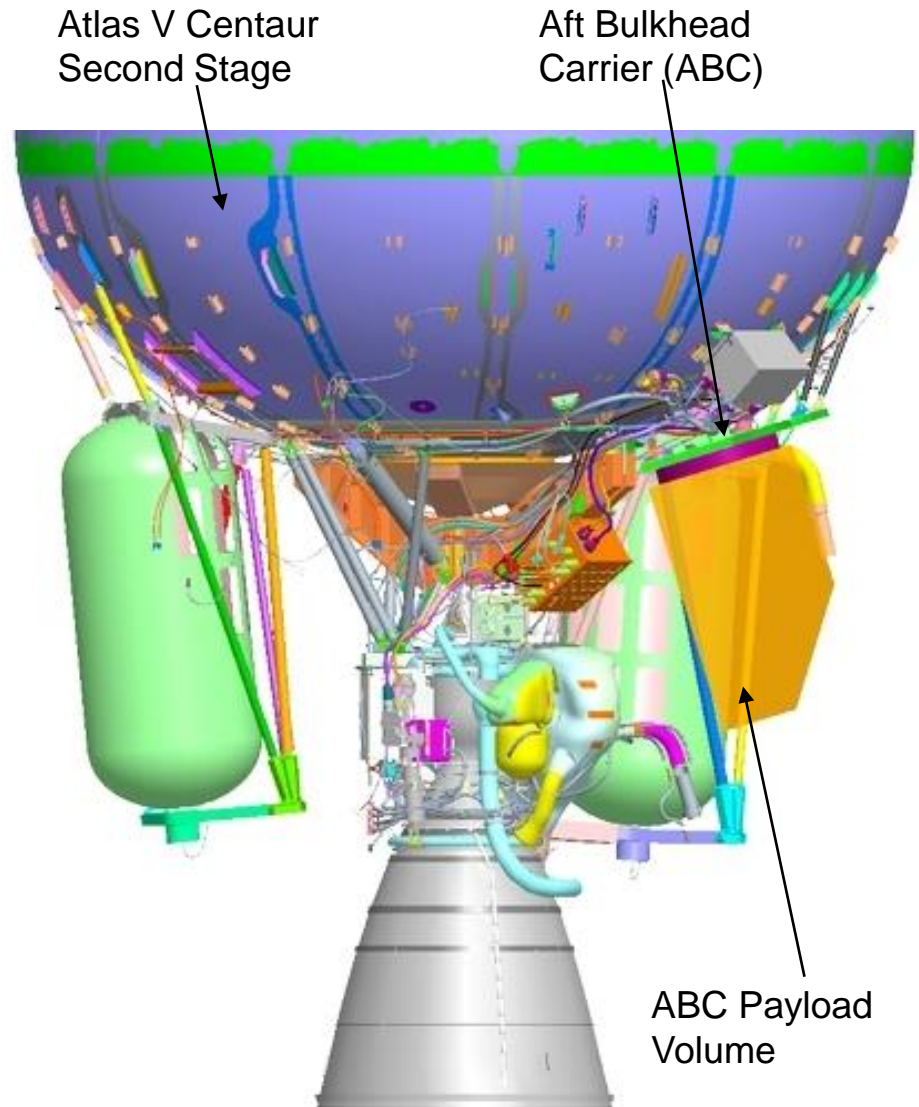

CubeSat Delivery System Evolution

Flight Proven Design Evolution / Standardization

ABC with NPSCuL

- Composite plate design
- 8 P-POD / 24U CubeSat
- Flight-proven; flown 4 times

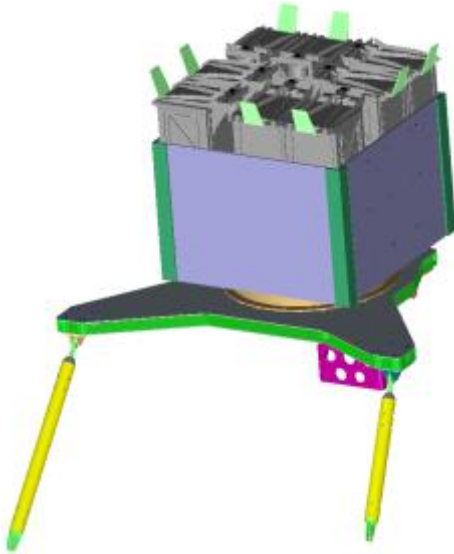

ABC with NLAS

- Composite plate design
- 12U CubeSat capacity
- Flight Proven: Worldview-4/ENTERPRISE
- NASA MarCO configuration

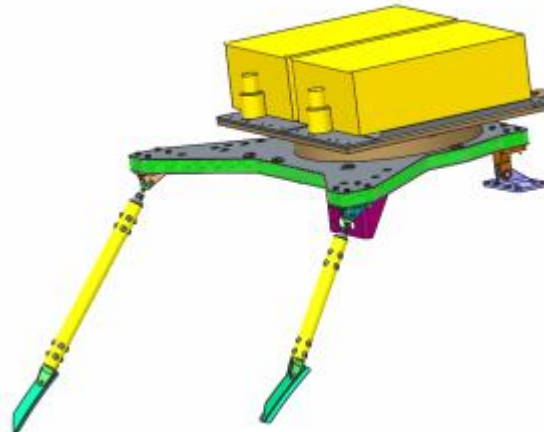

CubeSat Express / NLAS

- Aluminum plate and strut design
- 4-6U / 24U CubeSat capacity
- 2017 Initial Launch Capability



- NPSCuL: Naval Post-Graduate (NPS) School CubeSat Launcher
- NLAS: Nanosatellite Launch Adapter System

CubeSat Express Operation

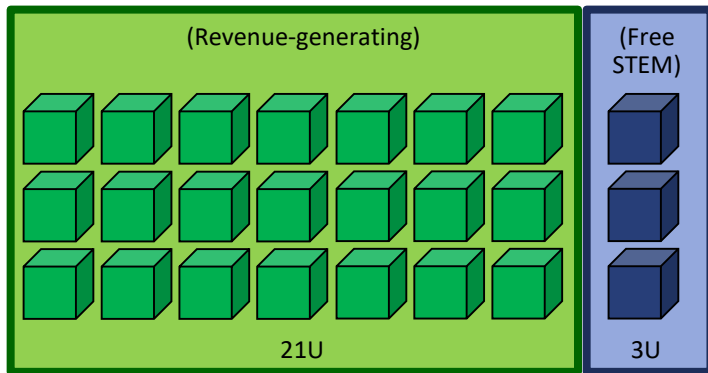

Tyvak APIC Marketing,
Selection & Integration

**24U
capacity per
Launch**

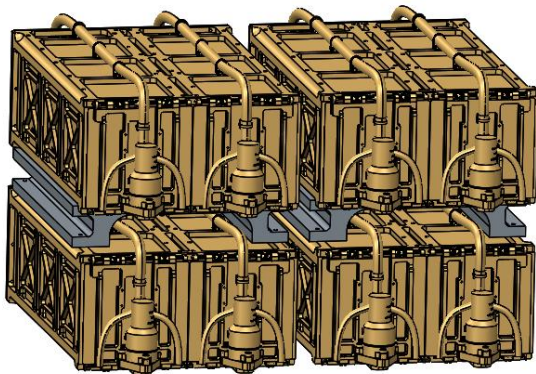

Four 6U NLAS Dispensers
Reference architecture

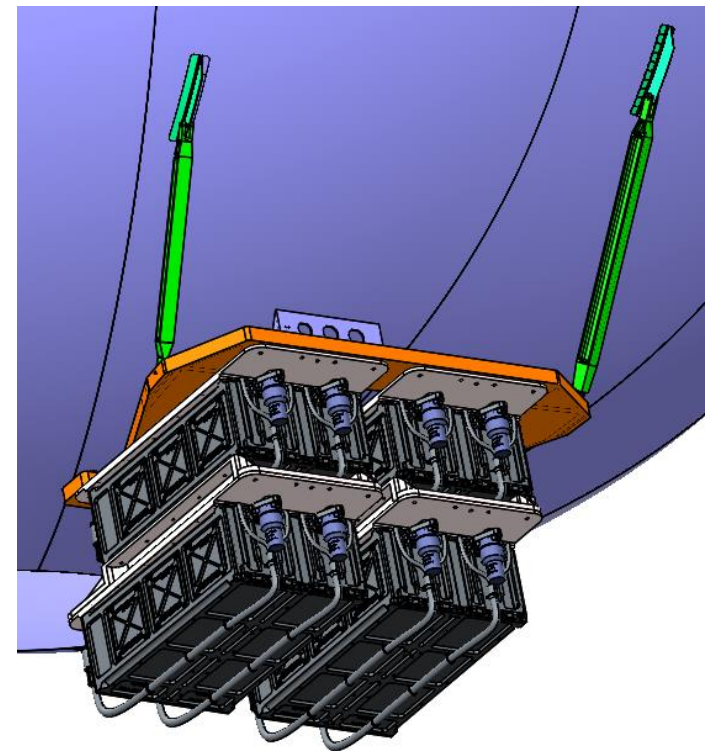

In Work Development Update

- ❑ Final Design for 24U CubeSat Express,
 - 4x 6U Express Configuration
- ❑ Implementing Class Analysis for Loads and Thermal Environments
- ❑ Developing CONOP for 12U Dispensers
- ❑ Preparing for Centaur Park-Orbit Separation Study
 - Optimize CubeSat Orbit and Useful Life
 - Reduce Risk in Separation Events

Continuing to Enhance Capabilities

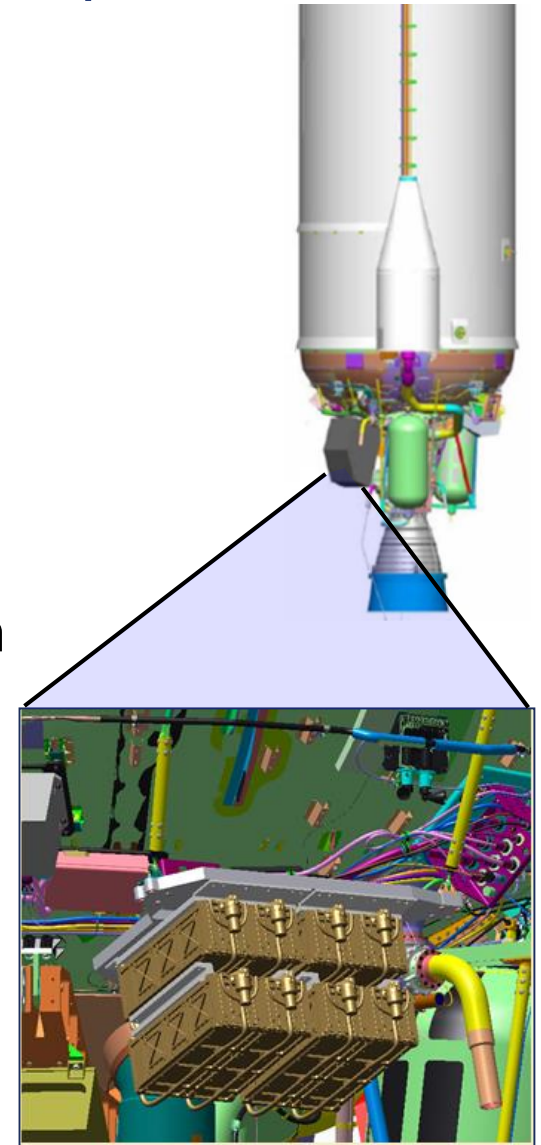

CubeSat Express Near Term Flight Option Performance Assessment

Vehicle Configuration Baseline Definition

Mission Requirements

(Primary SV Mass, ESPA Configuration, Mission Orbits, OCU Circuits Req'd, ILC)

Performance Assessment (Baseline 235 lbs as part of Centaur Vehicle)

Can Performance be achieved without an SRB, just for CubeSat Express?

No

**CubeSat's
Not Flown**

Are sufficient Ordnance Circuits available with Primary SV (~13% use more than 4 OCU Circuits)

Identify availability of 8 or 4 CubeSat Express Door Opening Circuits Available

Orbit Assessment – Review option of a non-optimal Park Orbit (425km x 1000 km) to extend CubeSat Useful Life

Coordinate CubeSat Flights:

Orbits (Park or Final), Available Door Openings, & ILC

Anatomy of a CubeSat Mission

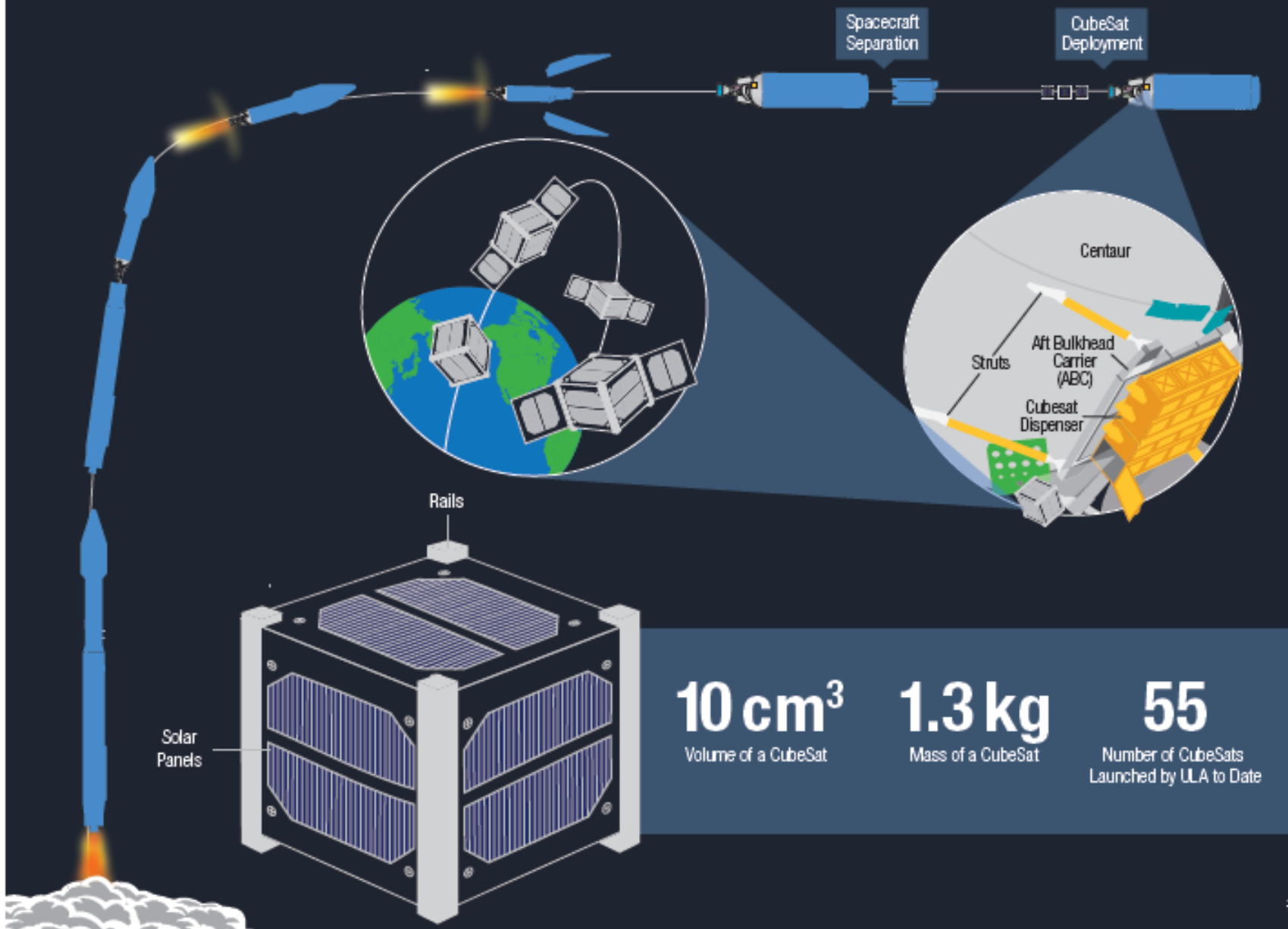



America's Ride to Space