

A Segmented, Deployable, Primary Mirror for Earth Observation from a Cubesat Platform

Noah Schwarz, David Pearson, Stephen
Todd, Andy Vick, David Lunney, Donald
MacLeod – United Kingdom Astronomy
Technology Centre



A Segmented, Deployable, Primary Mirror for Earth Observation from a Cubesat Platform

- Who we are
- Why deployable optics for Nanosats
- How
 - To sense
 - To deploy and align
 - To test
- Current conclusions and next steps

Work funded by UKSA and DSTL



UK Astronomy Technology Centre (STFC)



Science & Technology Facilities Council
UK Astronomy Technology Centre

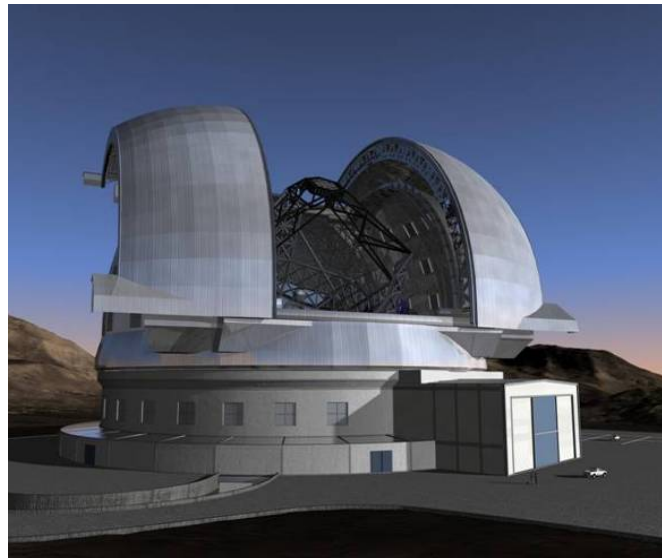
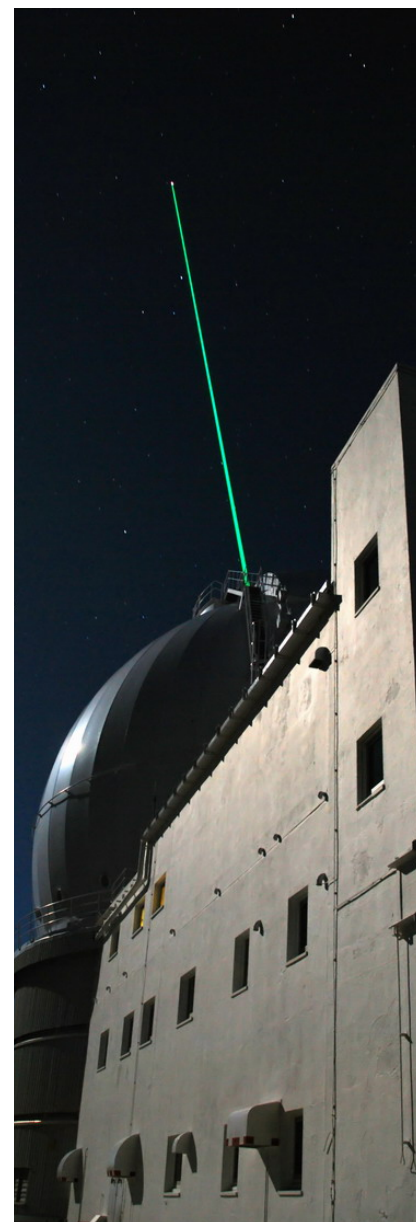
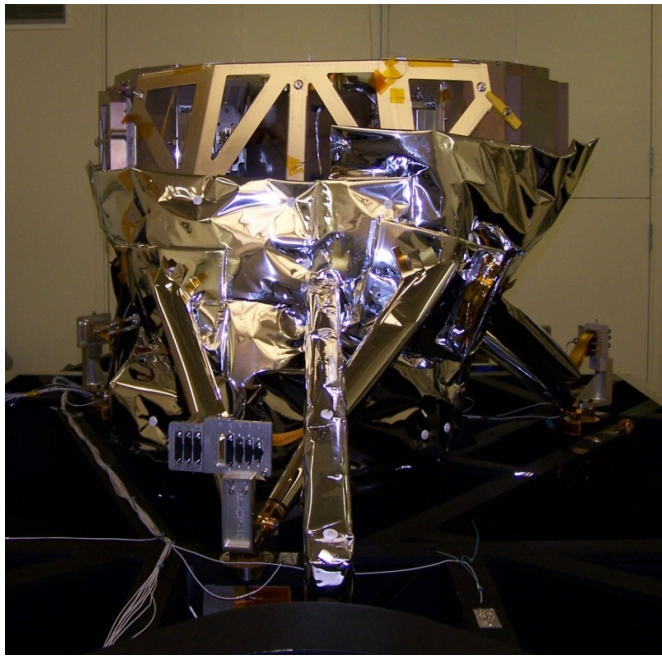
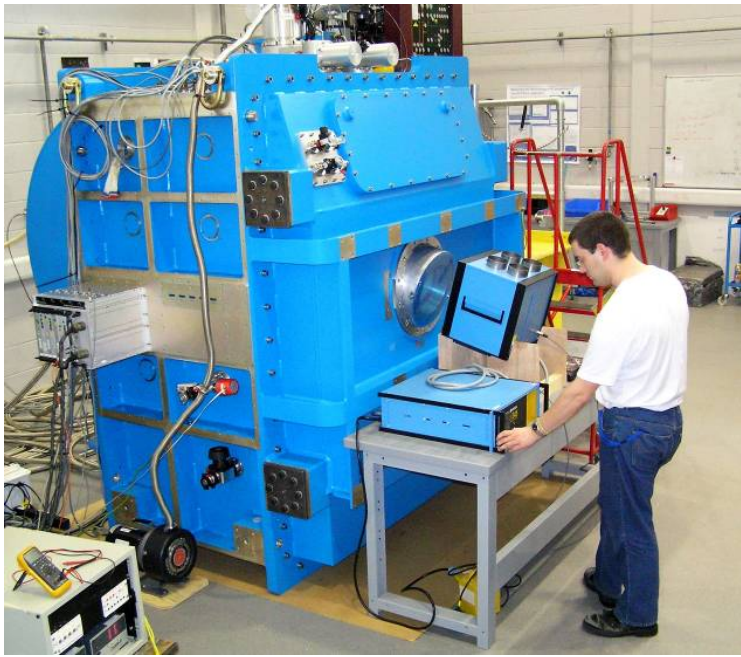

Why deployable optics for Nanosats

2.1m resolution



**10cm aperture
at 350km**

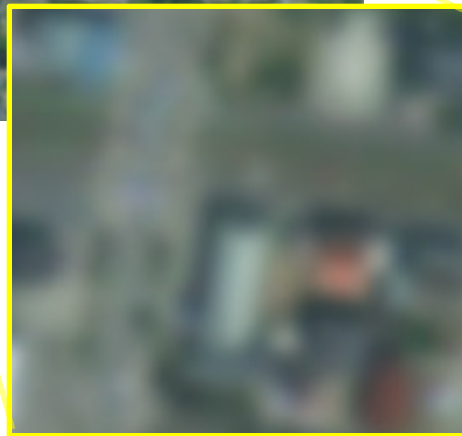

0.7m resolution



**30cm aperture
at 350km**



Solution: deployable optics

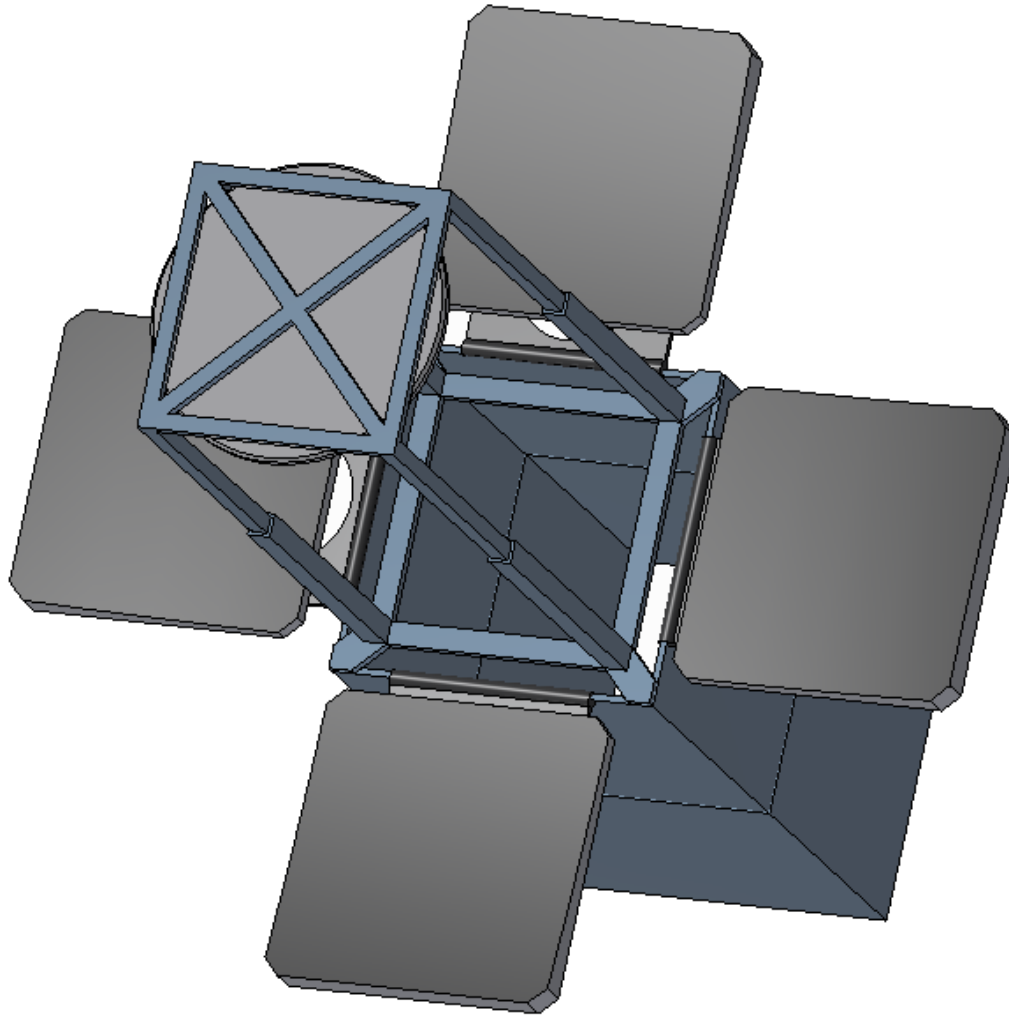

The spatial resolution is limited by the aperture

$$R(\text{radians}) = 1.22 \frac{\lambda}{D}$$

So a bigger aperture provides a finer spatial resolution image, and it increases the light gathering power $\propto D^2$



Issues and limitations

- To achieve the resolution you need to align the mirrors to $\lambda/10$, = 50nm in the visible.
- To turn this resolution into a ground sample you need to take account of ground speed
 - Sub mS exposure times
- The reference image is an extended source, as opposed to a point source.....
- Plus all the usual limits (power, space, ...)



Sensing optical aberrations

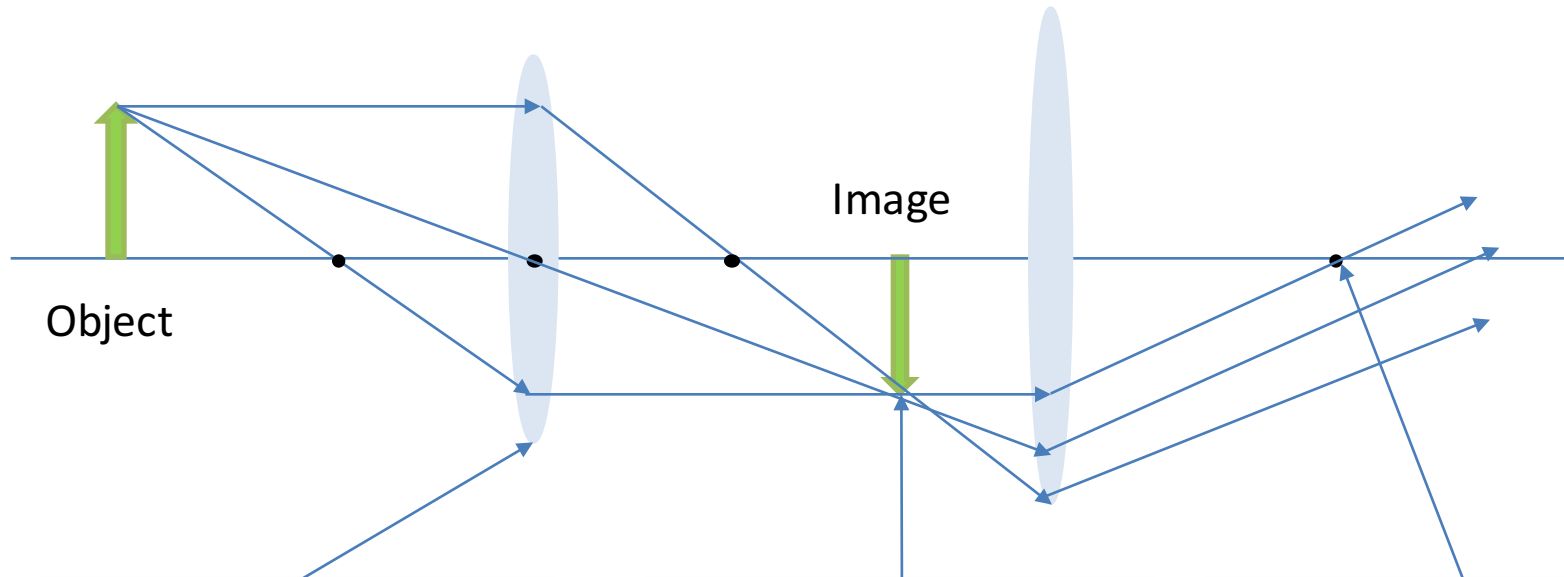

Measure the optic (the mirror) itself

Need to have a reference object as large as optic, or be very far away, or use local sensors (10nm!)

Measure the image

Not a 1:1 relationship between phase and image, forming an image loses information

Measure the wavefront (the phase/amplitude)

Needs extra hardware, uses up signal (in practice) and can be compute intensive



Simulating metric response

Simulation strategy

- OpticStudio (Zemax)
 - Generates diffractive PSF
- Matlab
 - PSF convolved with scene (Assumes spatially invariant PSF)
 - Calculates image sharpness metrics

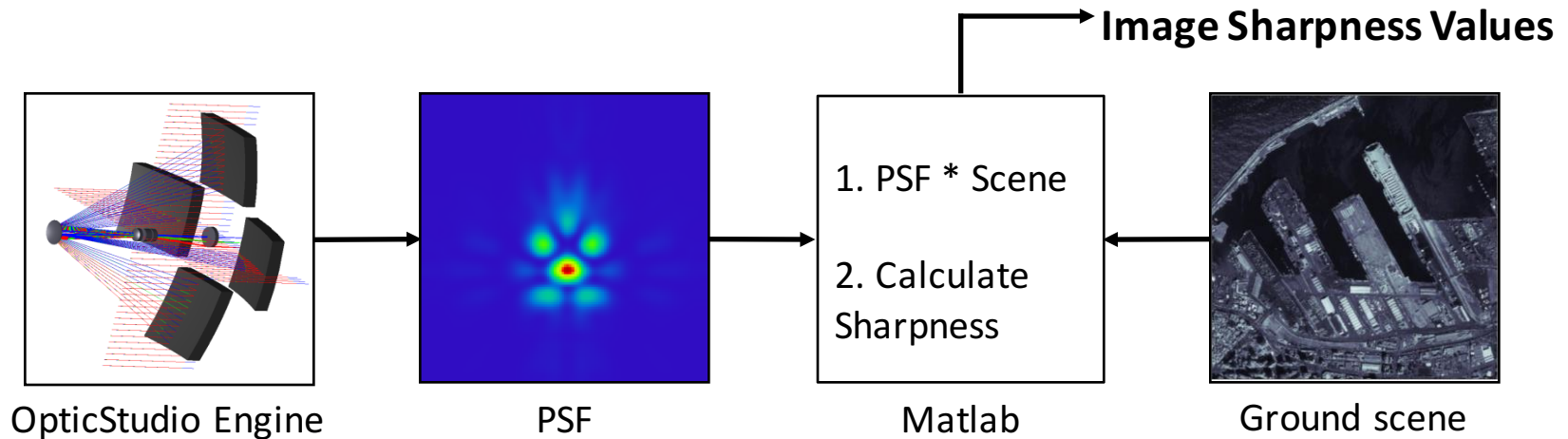
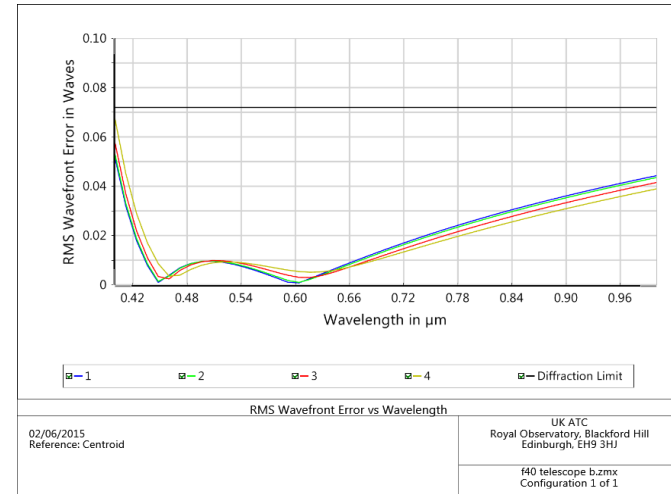

So many metrics

- What is a good metric to use?
 - Square intensity
 - Standard deviation
 - Edge detection filter: Sobel
 - Haar wavelet
 - Frequency method
 - ...
- Monotonicity better in practice than we suspected
- Sensitivity and scene independence are the key issues.

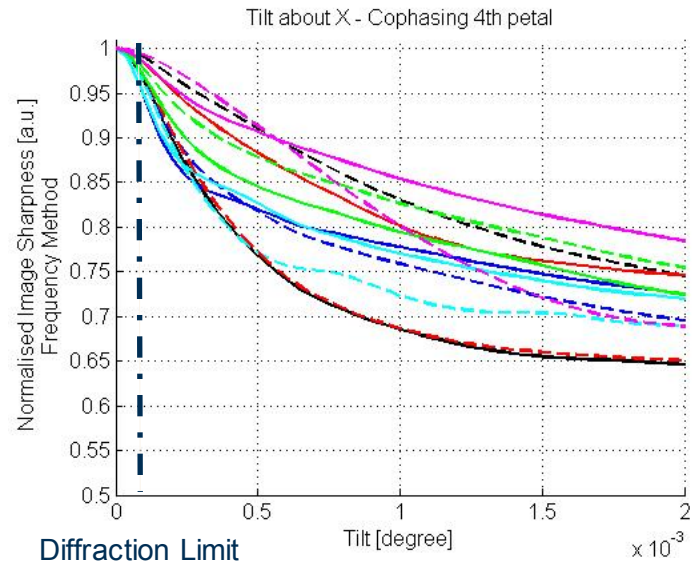
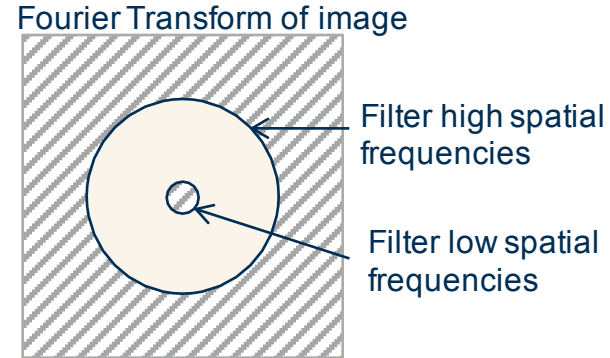

Bread-boarding the system

A high-precision deployment and adjustment strategy that can operate in space environments is required

The movement is created using high force piezo motors and guide flexures

Mechanical requirements		Adjustment resolution	Adjustment stroke	Deployment repeatability
DOF	Tip	$\pm \lambda/14$ (± 45 nm)	1 mm	± 10 μ m
	Tilt	$\pm \lambda/14$ (± 45 nm)	1 mm	± 10 μ m
	Piston	$\pm \lambda/14$ (± 45 nm)	1 mm	± 10 μ m

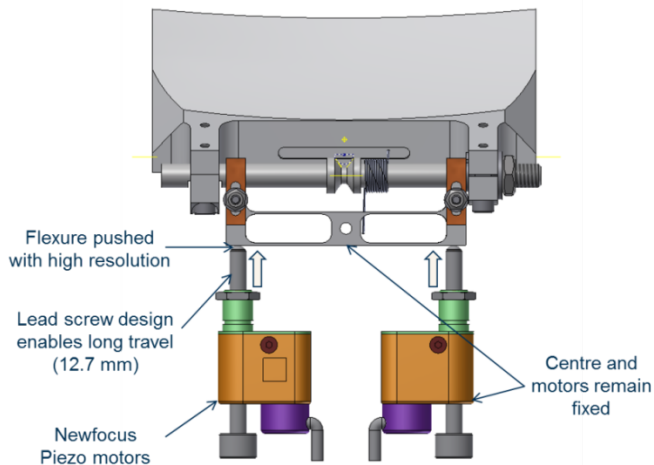

- Three motors on each mirror are required to provide tip/tilt/piston performance
- Mirror is suspended by a hinge on machined parallel flexures
- Piezo motors push the three flexible mounting points with a resolution of 30 nm

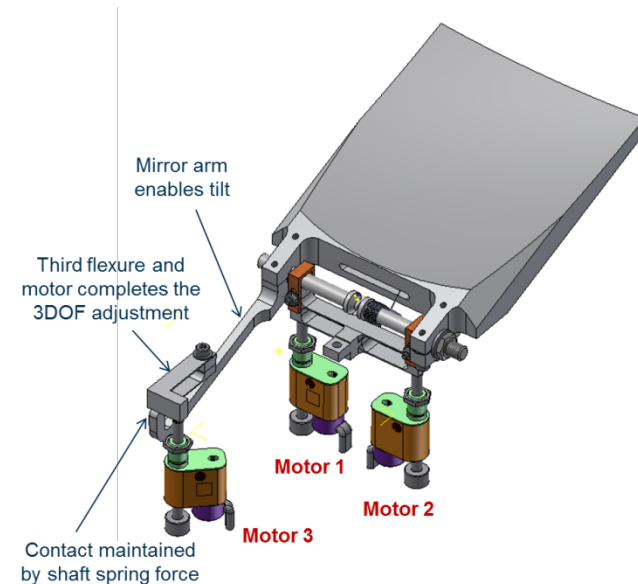

Mechanism performance

The mirrors are packaged into a 1.5U volume prior to deployment. Deployment can be initiated simultaneously or individually.

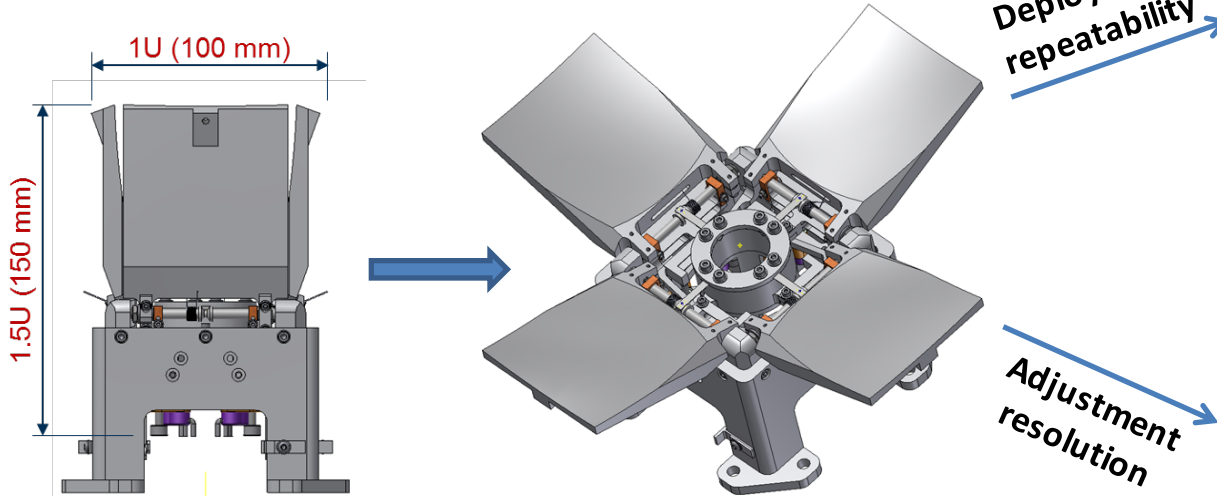

Interferometric lab tests of the mechanisms show the deployment precision and adjustment resolution exceed the optical specification

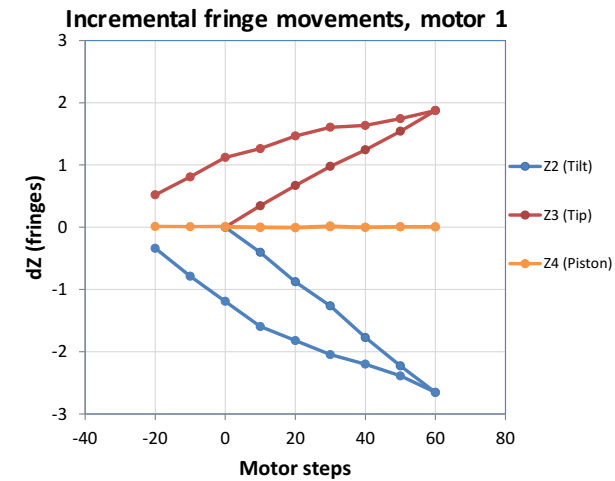
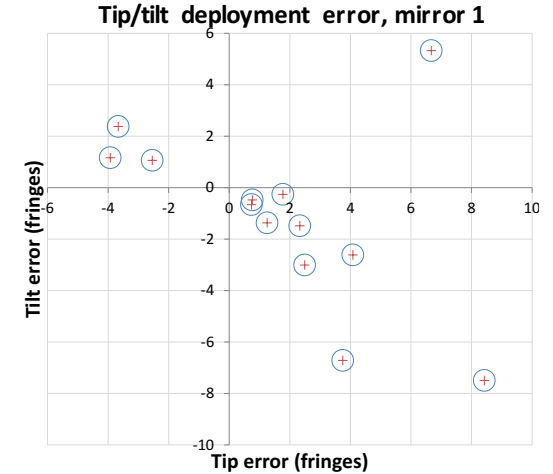

Testing the optics

- Phase-shifting Interferometer
- Scene based demonstration
 - Off-axis collimator
 - Fixed conjugate optics
 - On-axis collimator
- Dynamic scene demonstration
 - Digital light processor
 - Spectral testing

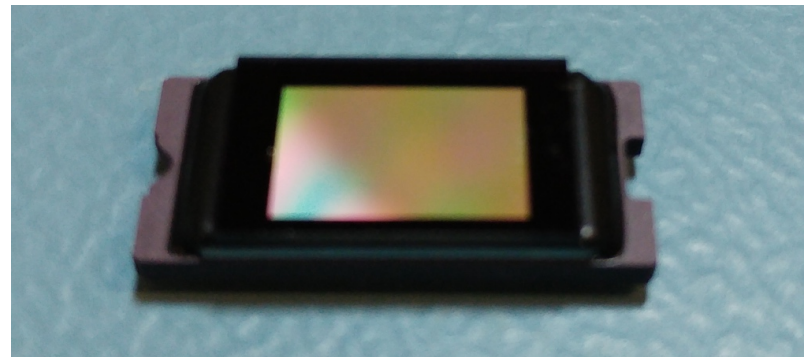
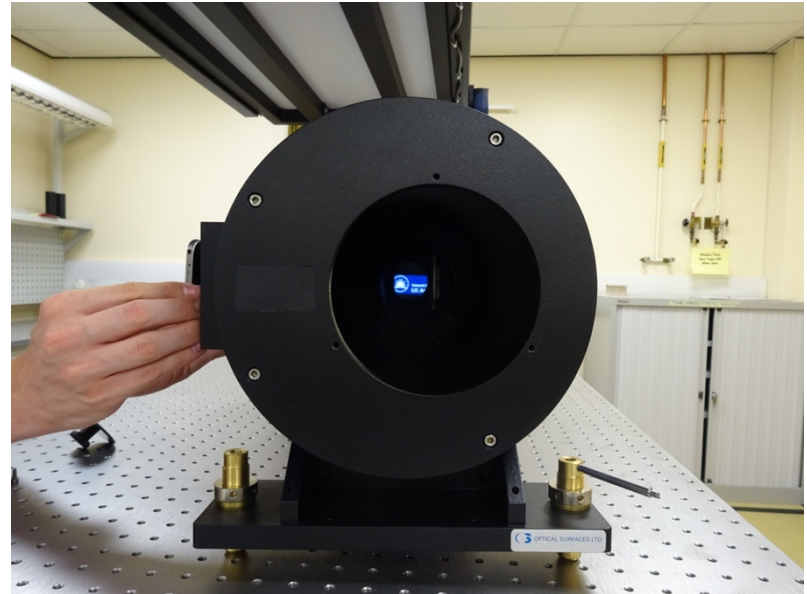



Science & Technology Facilities Council
UK Astronomy Technology Centre

Current conclusions and next steps

- Fitting deployable optical systems in a Cubesat is feasible.
- Alignment of optics using EO ground targets works, but is tricky;
 - Problems with feature dependence; SNR
- Next steps;
 - End to end breadboard
 - Minimize hysteresis effects: Displacement sensors
 - Static and dynamic scene tests – either fixed conjugate optical system or on-axis collimator.
- Once the method is established there are lot's of potential implementations.



Thanks for listening

Andy Vick, UK ATC (STFC)
<Andy.Vick@stfc.ac.uk>

