



Atmospheric & Space Technology Research Associates LLC

www.astraspace.net



Electric Field Instrumentation for CubeSats

Sunday, August 9th, 2015

Marcin Pilinski¹, Geoff Crowley¹, Chad Fish¹, Charles Swenson², Erik Stromberg³

¹ASTRA LLC.

²Utah State University

³SDL

- **The Need:**

Distributed multipoint measurements of the *electric field* in the space environment.

- **A Solution:**

One way to affordably achieve these observations is to make use of constellations of miniature spacecraft with miniature instrumentation.

- **Technology Gap:**

New low SWaP instrumentation for observing DC electric fields suitable for flight on spacecraft as small as CubeSats -> Instrument is the CubeSat

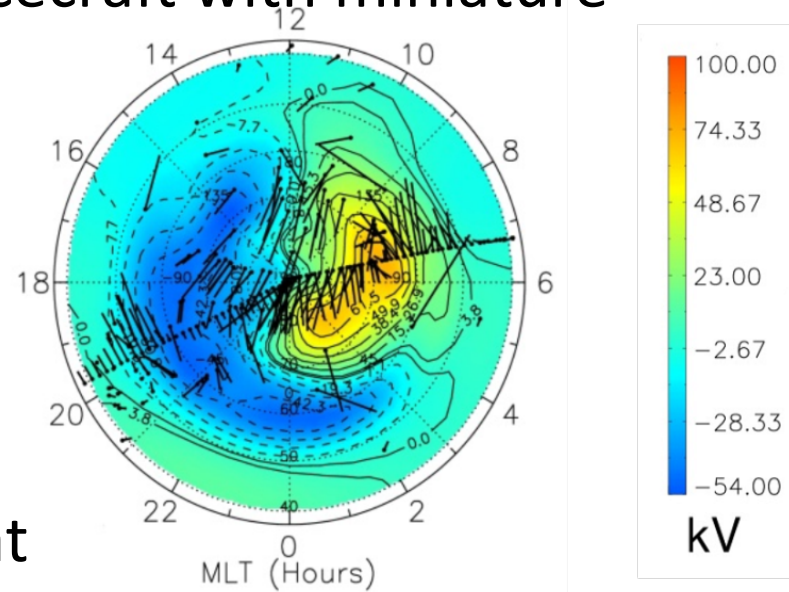

No Electric Field Information

No Electric Field Information

Electric Fields Assimilated into AMIE

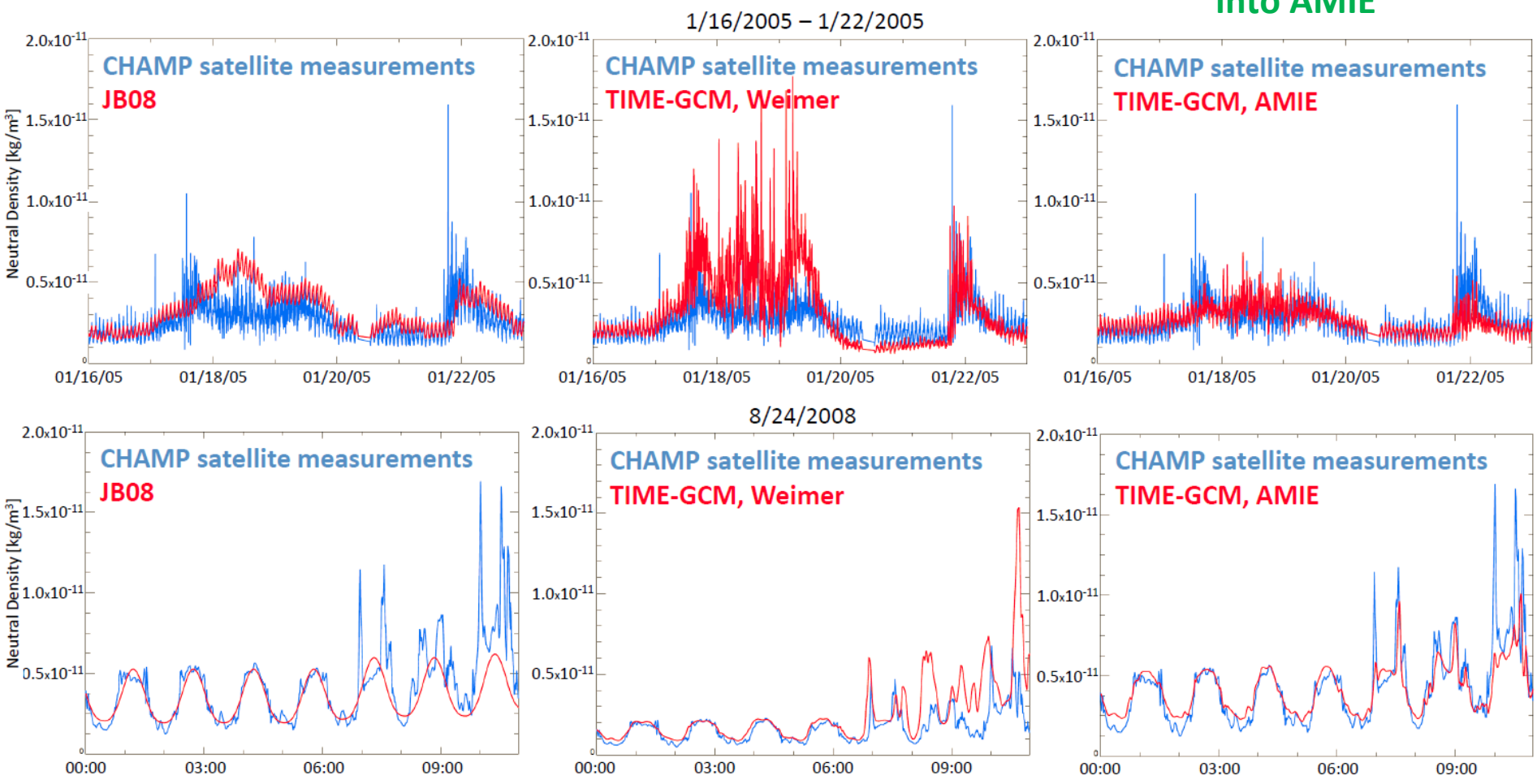

| Quantity | Requirement | Goal |
|----------------------|--------------|----------------|
| Range | 0-150 mV/m | 0-250 mV/m |
| Precision | ± 2 mV/m | ± 0.1 mV/m |
| Accuracy | ± 3 mV/m | ± 0.1 mV/m |
| In-track Resolution* | 1.0 km | 0.1 km |

*unspecified for E-field in IORD, using values from the IORD-II B-field requirements.

Primary Objective: Measure ionospheric E-fields using a wire-boom double-probe on a spinning CubeSat platform.

Minimum Success Criteria:

- a) Deploy E-field booms, verify deployment
- b) Collect on orbit and download **50,000 minutes*** of E-field data that satisfies the measurement requirements of the IORD-II.

**over a 3-month period*

Dynamic Ionosphere CubeSat Experiment (DICE), NSF CubeSat

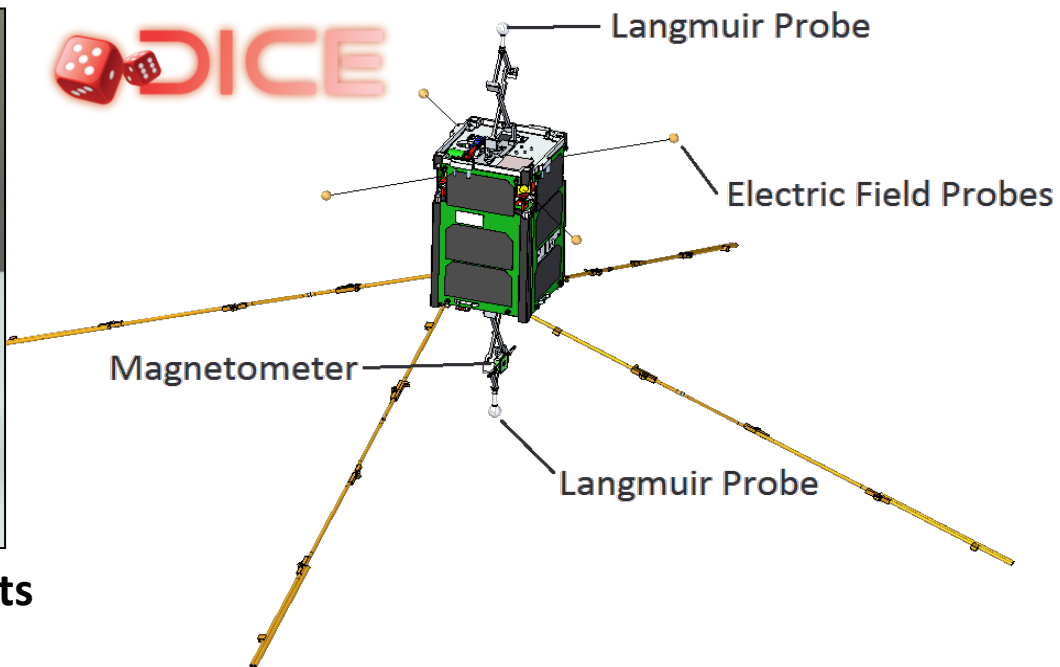
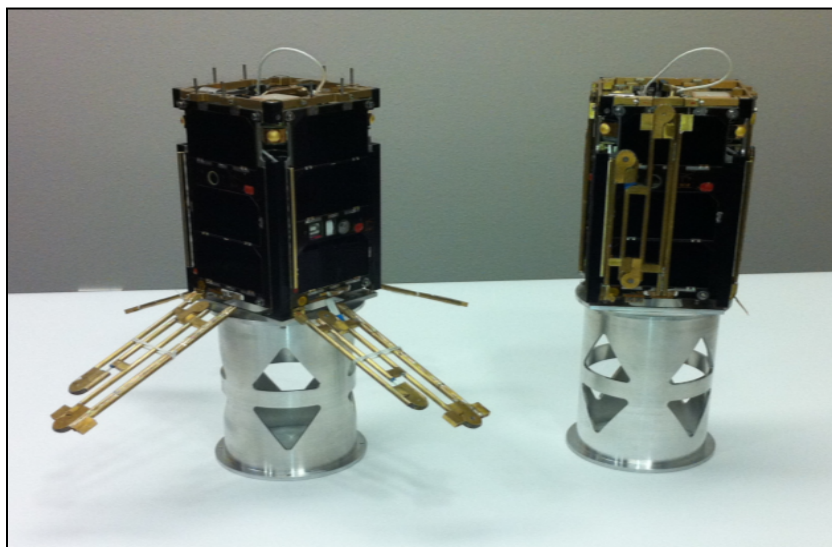

Above: Yahtzee and Farkle 1.5 U CubeSats with communications antenna deployment mechanism shown.

Two spinning spacecraft I (Yahtzee and Farkle) launched from Vandenberg on October 28th. Leader–follower with spin rate: ~ 0.2 Hz and 102° inc. 455x810km orbit

Electric Field ~ 0.2 mV/m, Double Probe Technique, 5 m wire booms (10 m tip-to-tip), ~ 80 Hz sample rate

Plasma Density $\sim 10^2 \text{cm}^{-3}$, Dual Langmuir Probes, ~ 80 Hz sample rate

Magnetic Field ~ 10 nT, ~ 80 Hz sample rate

Mission Update: DICE Makes First CubeSat Observations of an SED

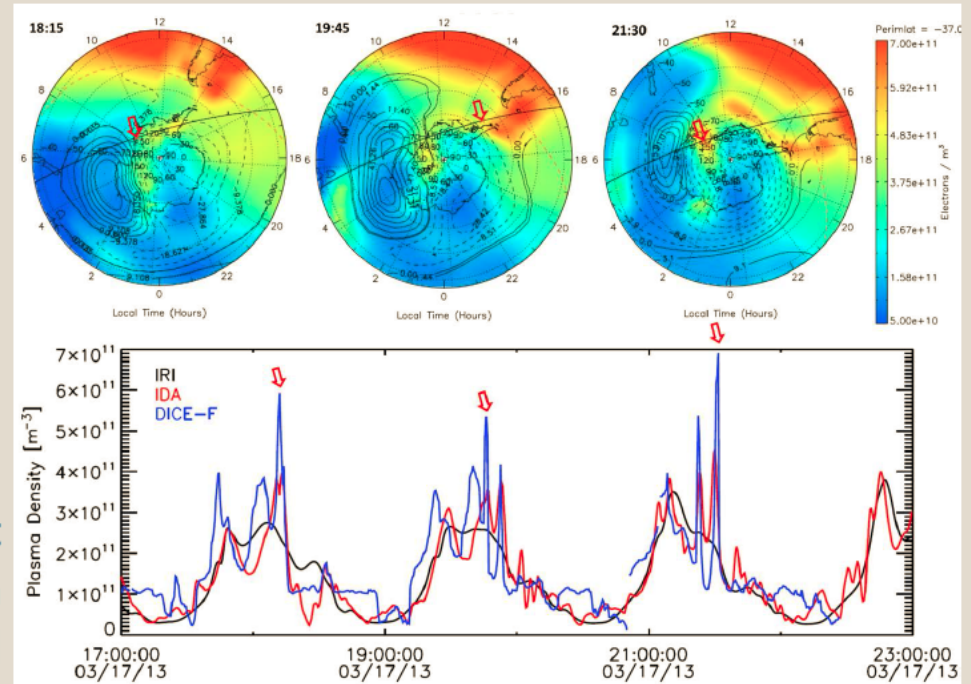
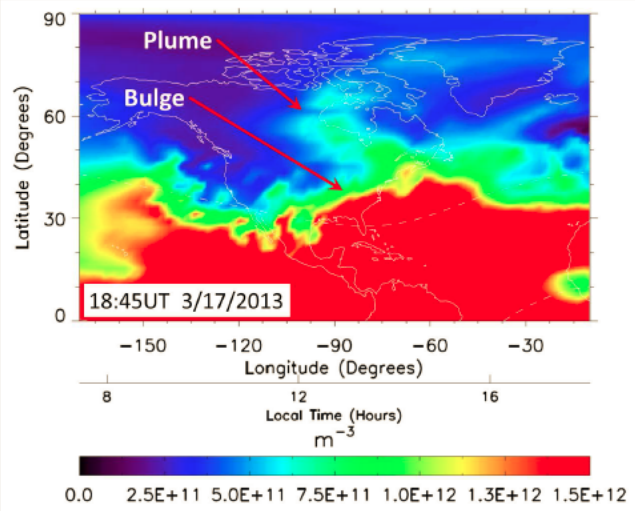

In March 2013, DICE made the first CubeSat measurements of Storm Enhanced Densities (SED, pictured above) in the ionosphere. IDA4D assimilation successfully reproduced the SED feature over the southern hemisphere (see Figure on the right). The SED evolution followed a trajectory wrapping around the AMIE-specified dusk convection cell.

Above: DICE plasma density observations compared with IDA4D assimilation of the south polar ionosphere. Note that the enhanced densities observed by DICE (red arrows in the bottom plot) correspond to when the DICE satellite passes through a tongue of ionization during successive passes (red arrows).

Mission Update: DICE Observes Field Aligned Currents

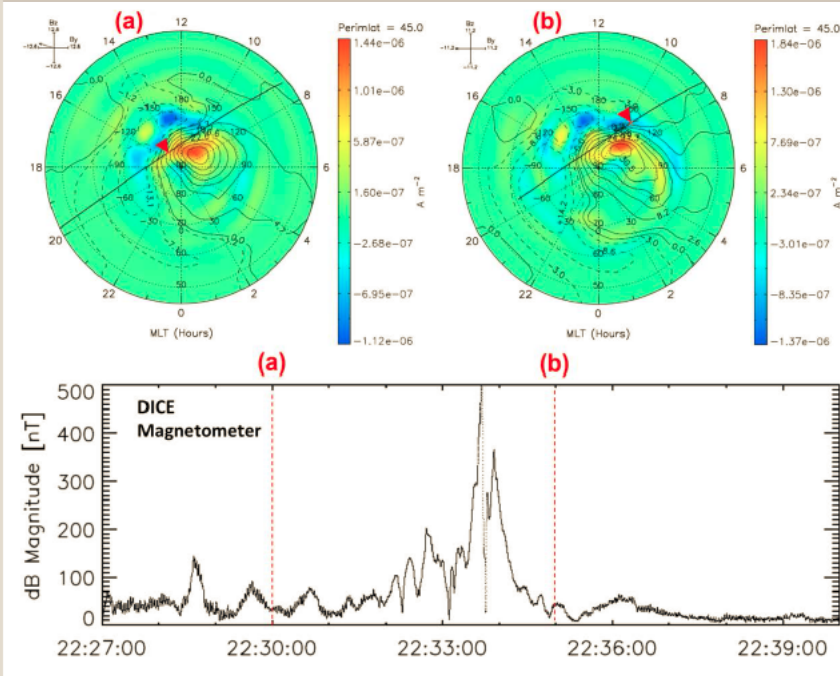

Above: AMIE reveals that the DICE ΔB event corresponds to a region of enhanced FACs in the cusp region.

On May 22nd, 2012, at 22:34UT one of the DICE satellites flew through an intense region of field aligned current (FAC) and detected the event with the body-mounted magnetometer. These measurements demonstrated for the first time that strong FAC's can be detected from a strap-down magnetometer on a CubeSat.

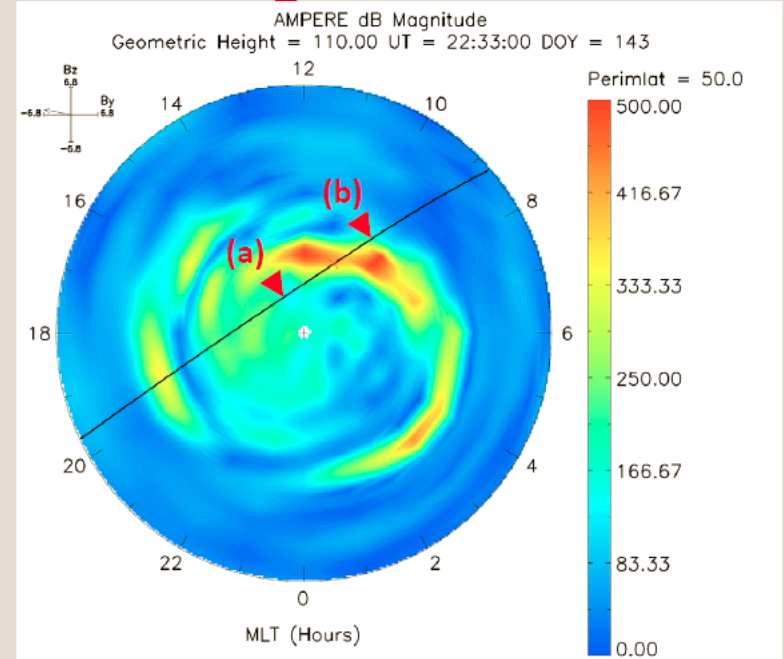

AMPERE ΔB magnitude (top) from spherical harmonic fits performed by the AMPERE team (3° resolution) with DICE locations (red)

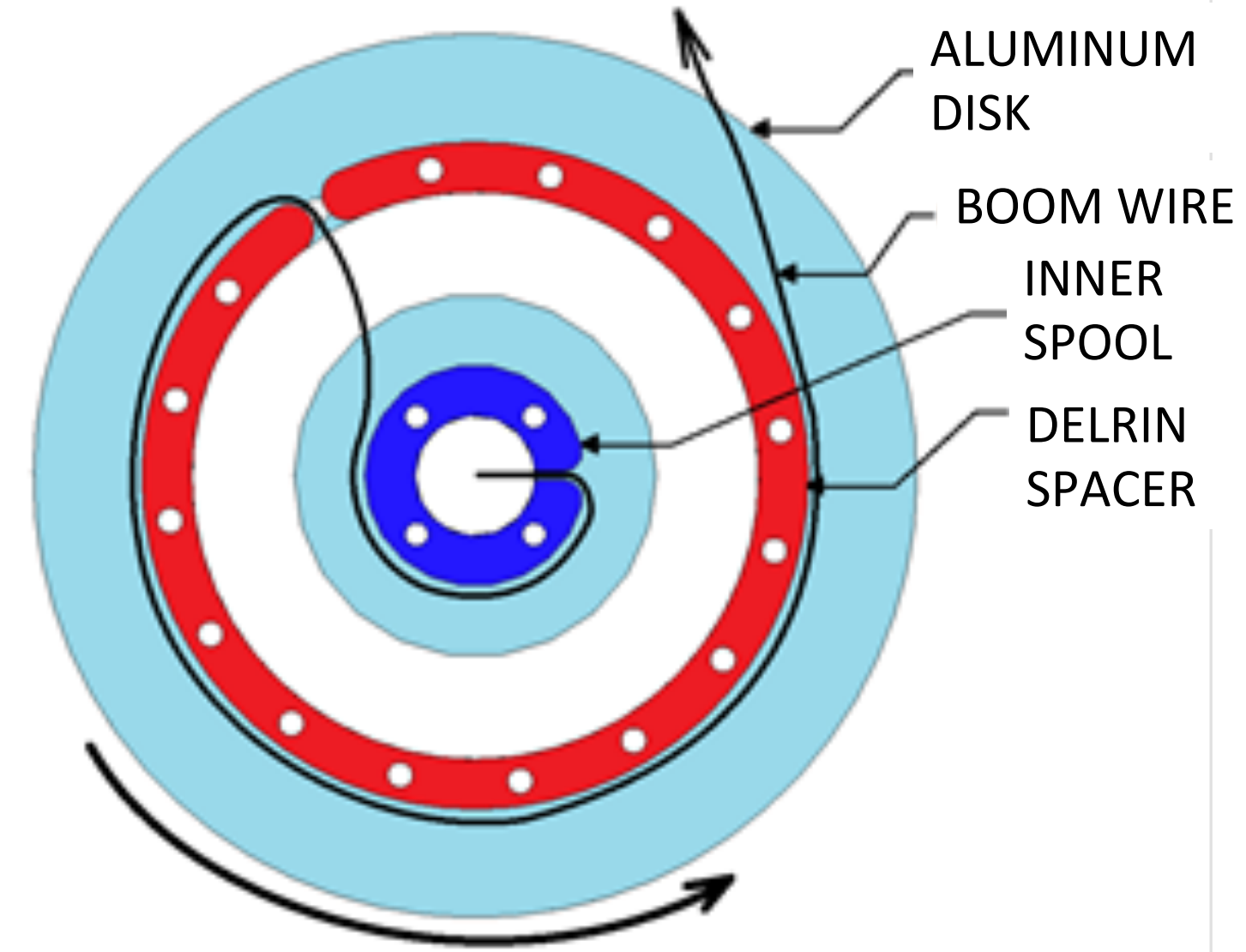

Lessons Learned from DICE - roadmap towards DIME



| DICE | DIME |
|------|------|
|------|------|

| | | |
|----------------------------|---|--|
| Telemetry rates of 16 kbps | <ul style="list-style-type: none"> • Demonstrated 3000 kbps with Wallops facility • Developed and demonstrated database conditioning and processing software (9GB down) | <ul style="list-style-type: none"> • Utilizing DICE heritage communications • Re-using database-processing software for DIME |
|----------------------------|---|--|

| | | |
|-----------------|--|--|
| Spin up to >1Hz | <ul style="list-style-type: none"> • Validated sun-sensor and magnetometer determination • Insufficient attitude observability during commissioning • Problems with deploying and locking the custom deployable mass-trim booms resulted in insufficient MOI margins as well as momentum coupling during the spin-up process. This prevented at least one of the spacecraft from spinning up • Could not exert sufficient torque authority for open loop control • Control periods were interrupted by low-power modes • Required more configurability to address sensing issues during spin-up • Demonstrated de-tumble algorithm successfully • Validated ground determination algorithms | <ul style="list-style-type: none"> • Using the same sun-sensor and magnetometer • Implemented gyro sensor, added additional sun-sensor and photodiodes for improved observability • Simplified mass-trim deployment and implemented independent COTS actuator, hinge, and spring designs • Increased MOI margin to >1.20 • Raised spacecraft stiffness • Improved spacecraft symmetry and fine-tuning control • Increased torque authority • Increased power margins • Implemented new control algorithms which are simplified and more configurable • Augmenting DICE ground-determination algorithms for DIME |
|-----------------|--|--|

| | | |
|-----------------------|--|---|
| Measure ion densities | <ul style="list-style-type: none"> • Measured on densities compared with IDA4D and IRI validating the Langmuir Probe • Langmuir probes successfully deployed but could be made stiffer | <ul style="list-style-type: none"> • Langmuir Probe electronics based on DICE heritage • Langmuir Probe mechanical design simplified and fundamental mode increased |
|-----------------------|--|---|

- Deployment Mechanism: Ratchet brake design did not allow for fast boom deployment. Now using a toothed brake
- Spool Design: Non-concentric outer spool/inner spool bushing caused excessive play. Enhancements will be reflected in the new design by incorporating precise ceramic bearings.
- Spool Design: Clearance between bearing cap and outer spool allowed for excessive rocking. Incorporated precise ceramic bearings.
- Spool Design: Spool winding was not repeatable, and had to be reset for each test, costing time. Design enhancements are reflected in the new by using a motor to enable winding and unwinding of the spool, a tensioner to maintain force on the cable, and a spool guard to prevent cable from slipping from the spool. During rewind
- Wire Boom: Coiling 5 meter wire is difficult. Already addressed in DIME design. Use of motor and independent spool segments which allow for independent adjustments of uneven cable lengths.

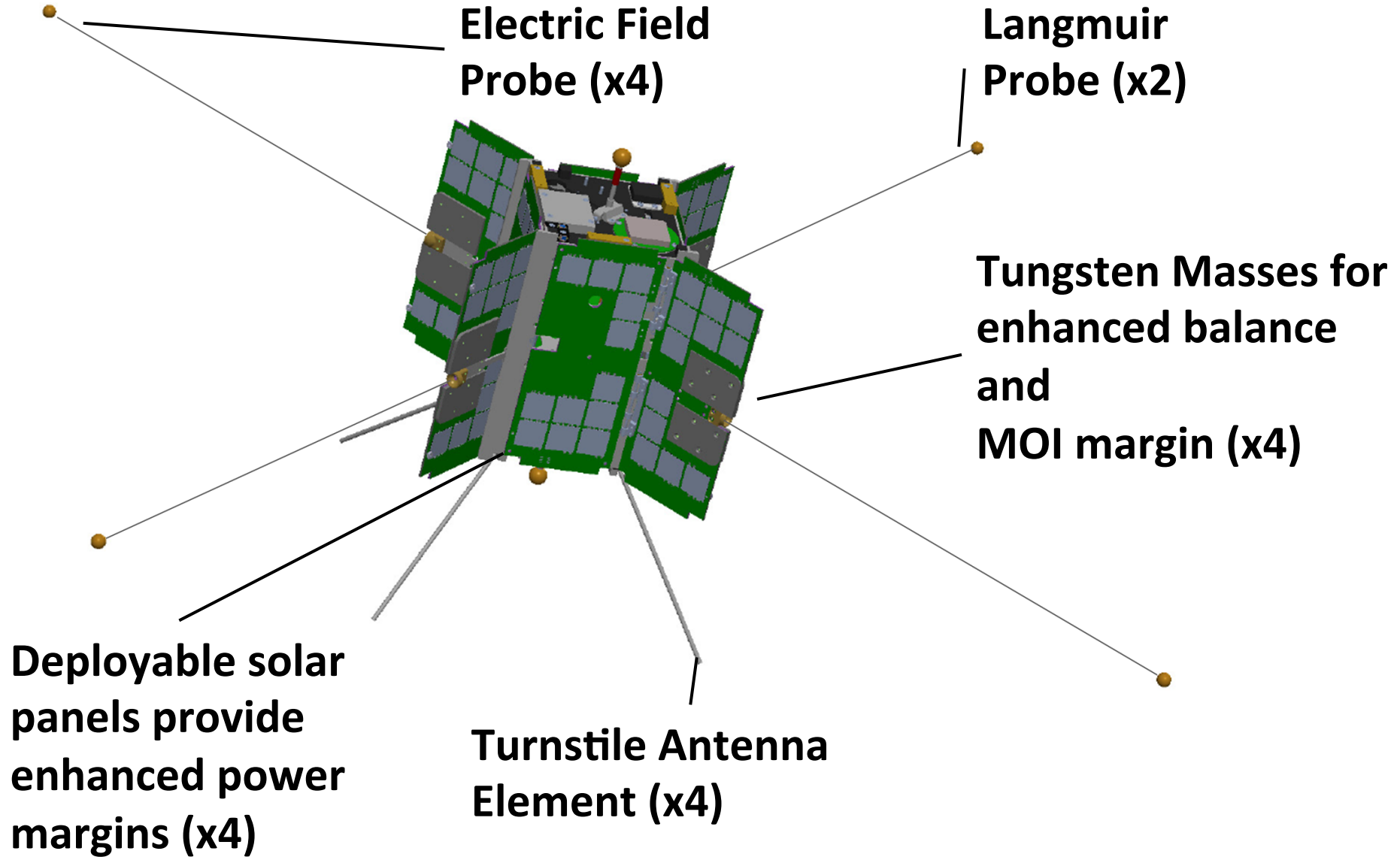

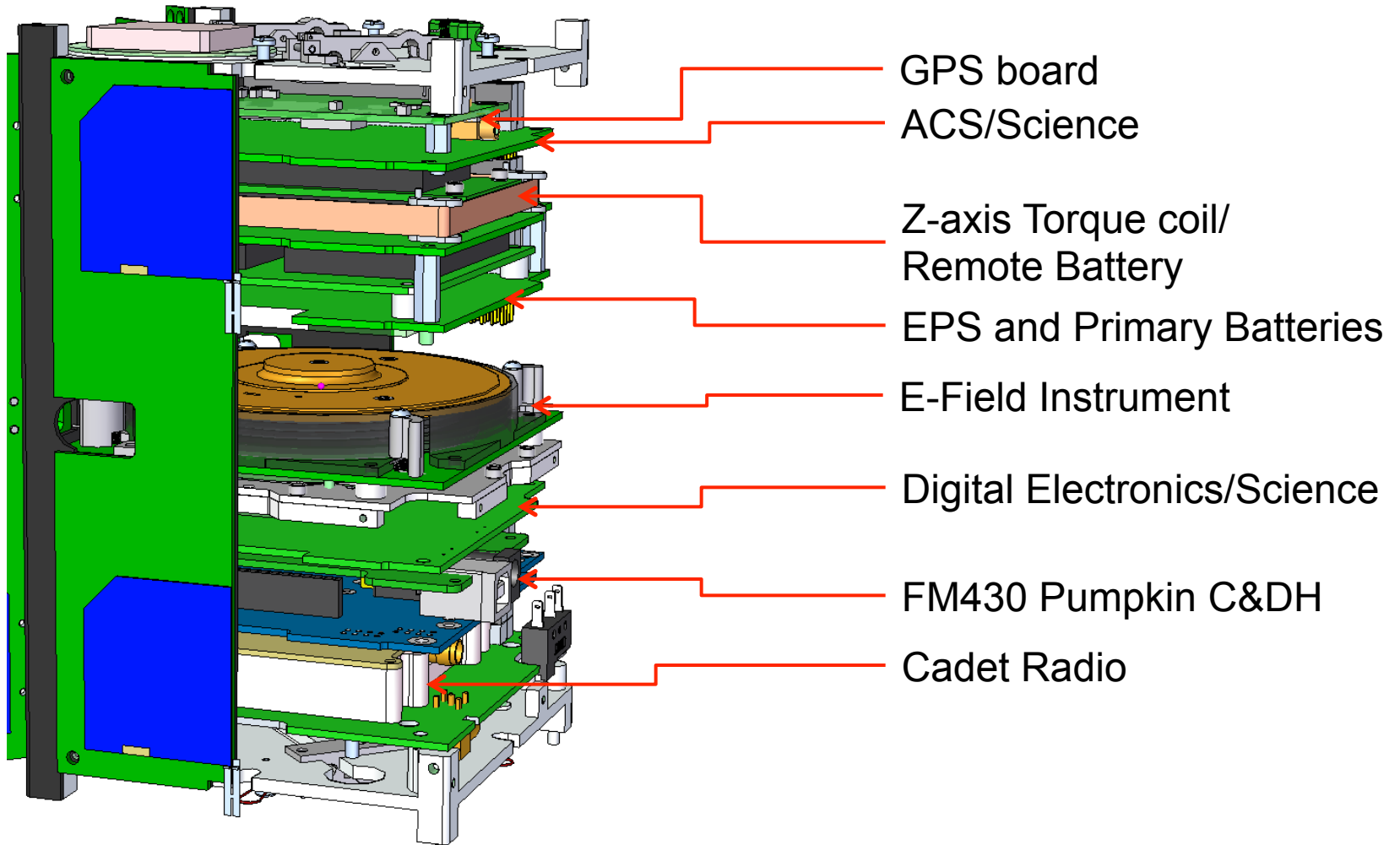

PCB Motor for DIME

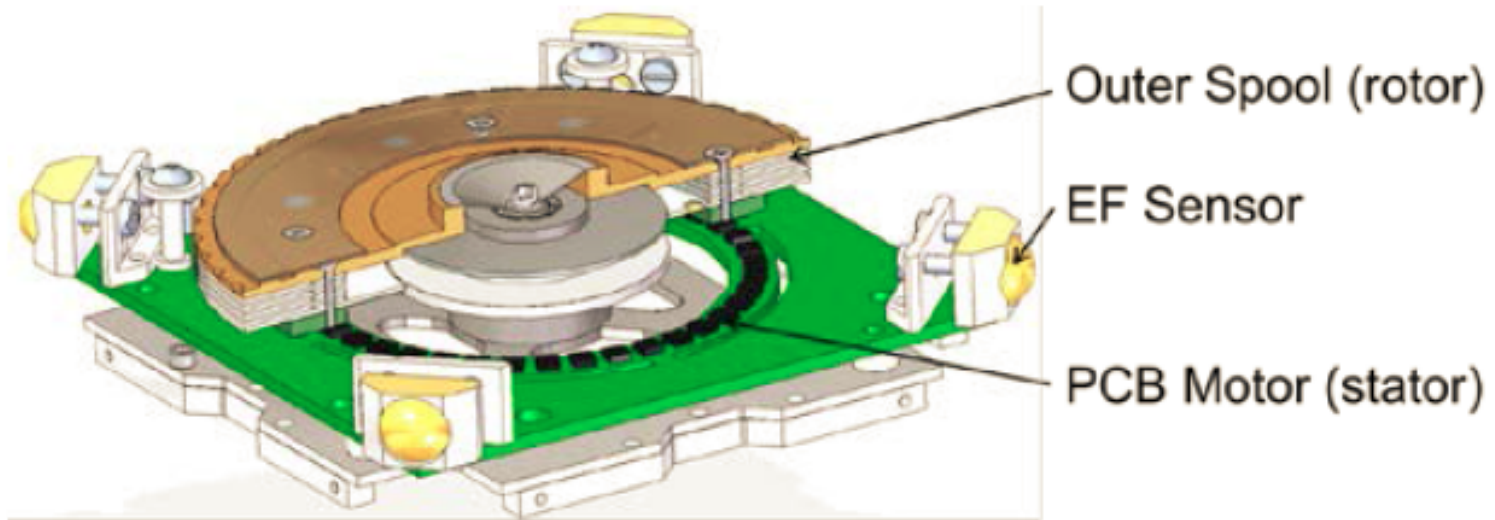
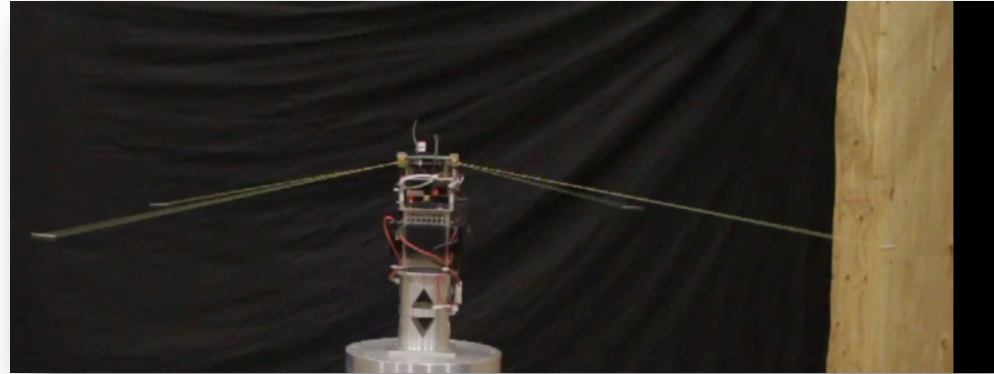

PCB Motor Concept for DIME

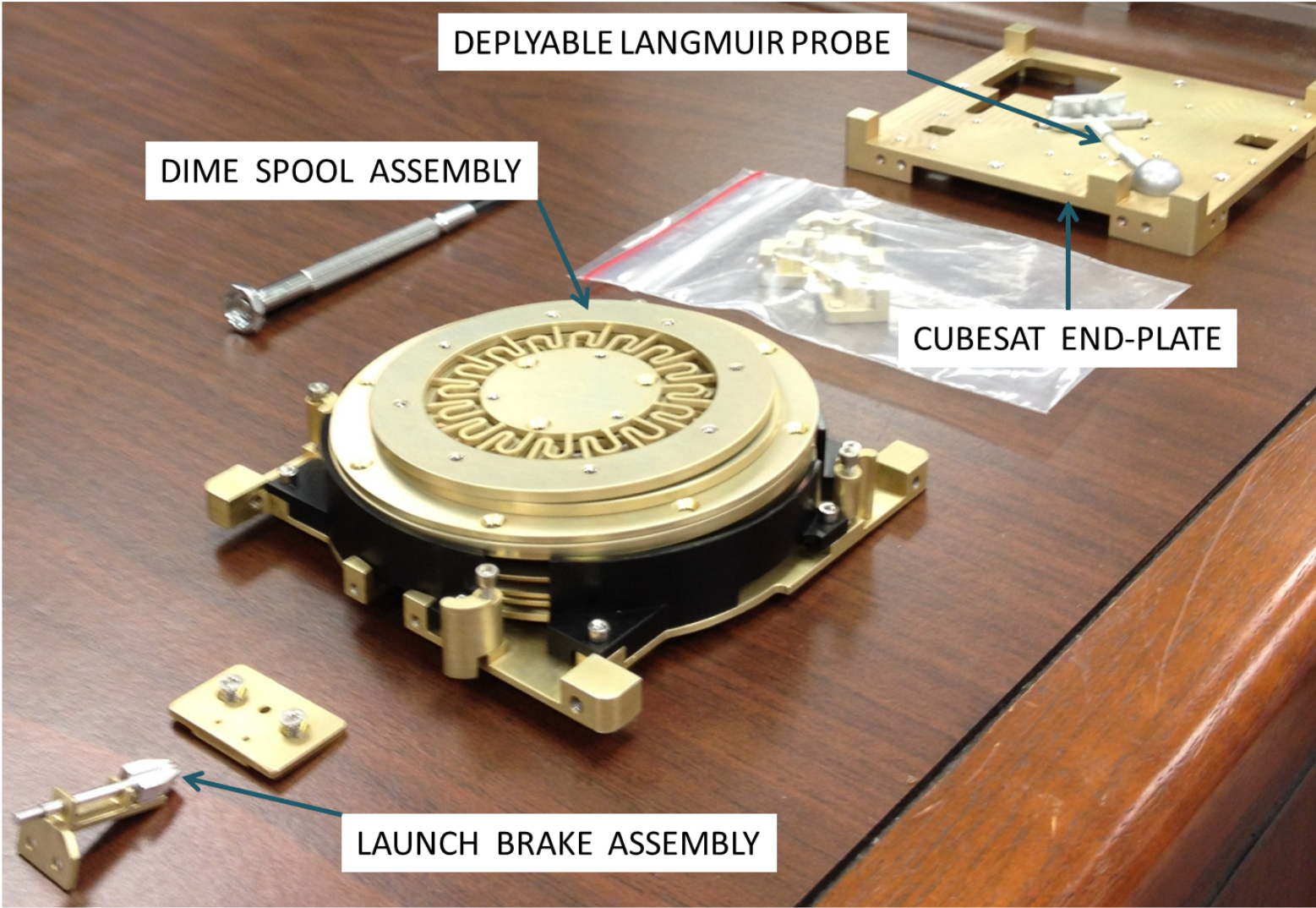

Auroral Structures Probes

❖ Science
 ❖ Technology
 ❖ Applications
Bringing It All Together



- Electric Field** 0.2-1000 mV/m, 4 m tip-to-tip wire booms, 379 Hz sample rate
- Electric Field Spectrometer** 16 Channels, 85-12.5k Hz, 23.7 Hz sample rate
- Plasma Density** 10^2 - 10^7 cm⁻³, Langmuir Probe, 379 Hz sample rate
- Magnetic Field** ~2 nT, 379 Hz sample rate

- *Launched December 2014, Poker Flat*
- *Payload in functioning testing*

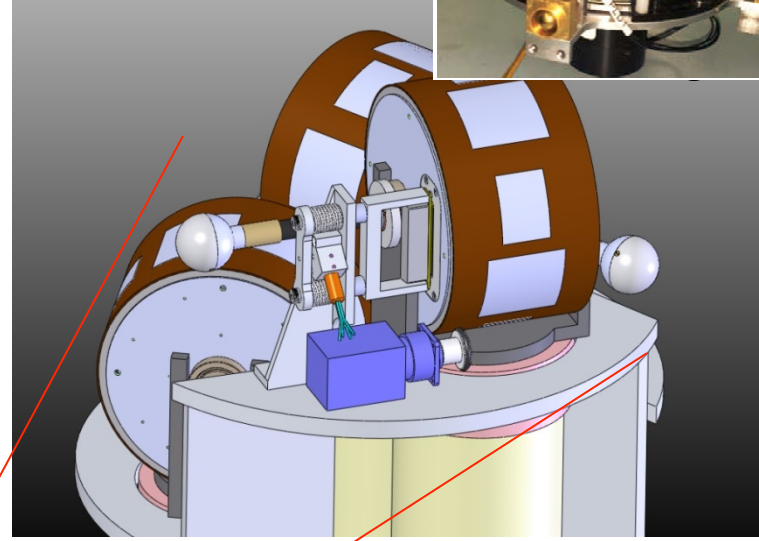
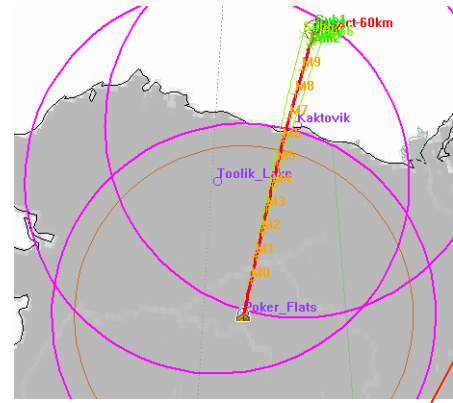
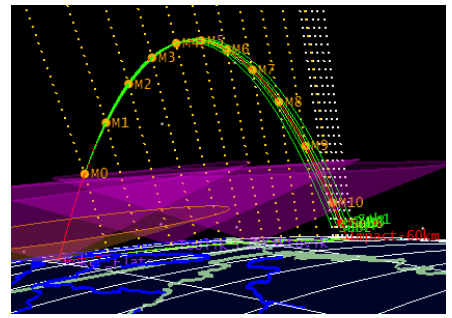
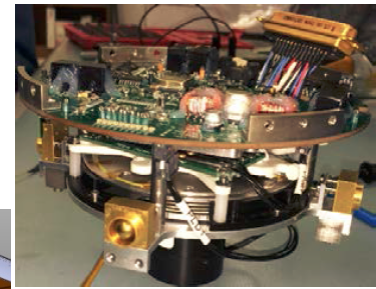

Six Sub-Payloads

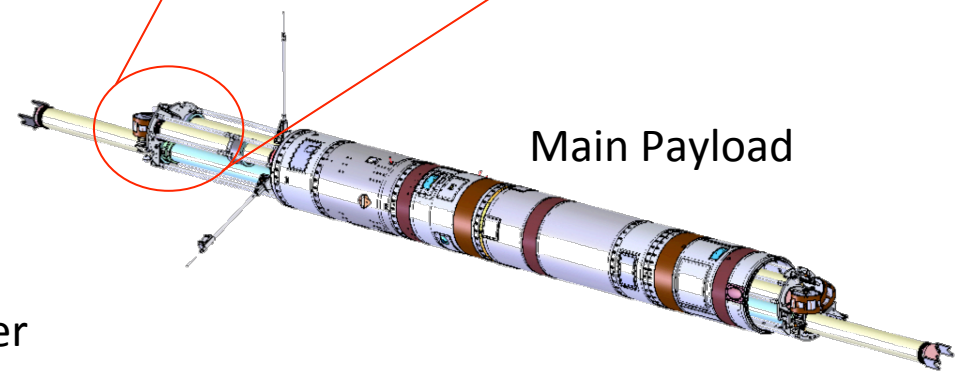
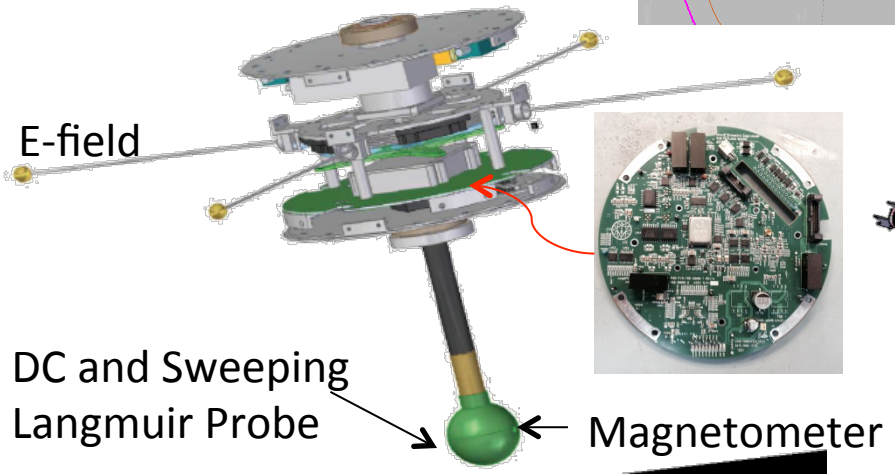

CLARA: Compact Long-boom and Antennae Release Assembly

❖ Science
❖ Technology
❖ Applications
Bringing It All Together

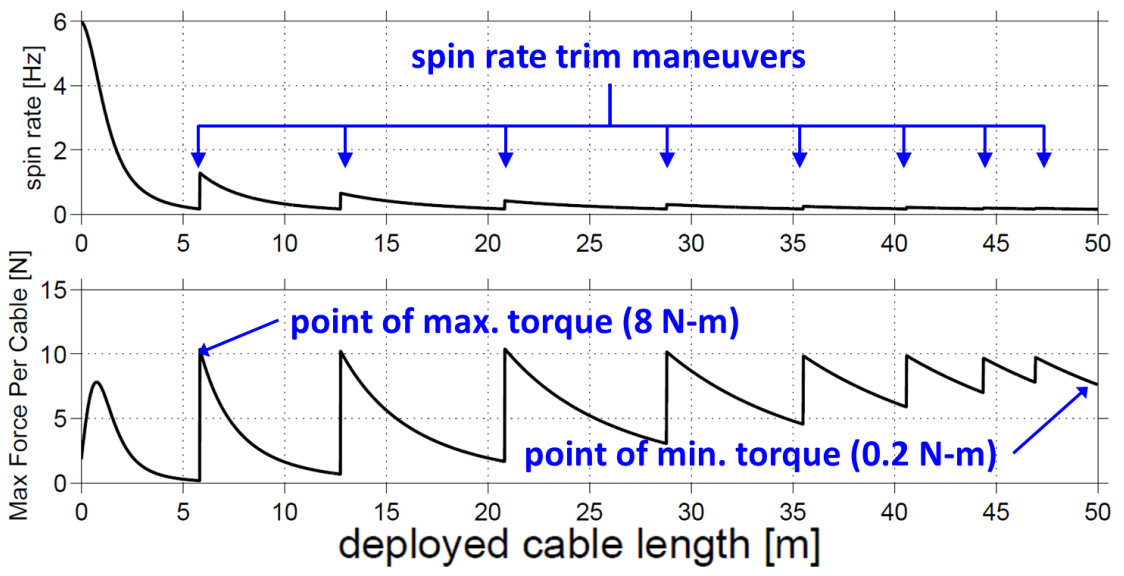
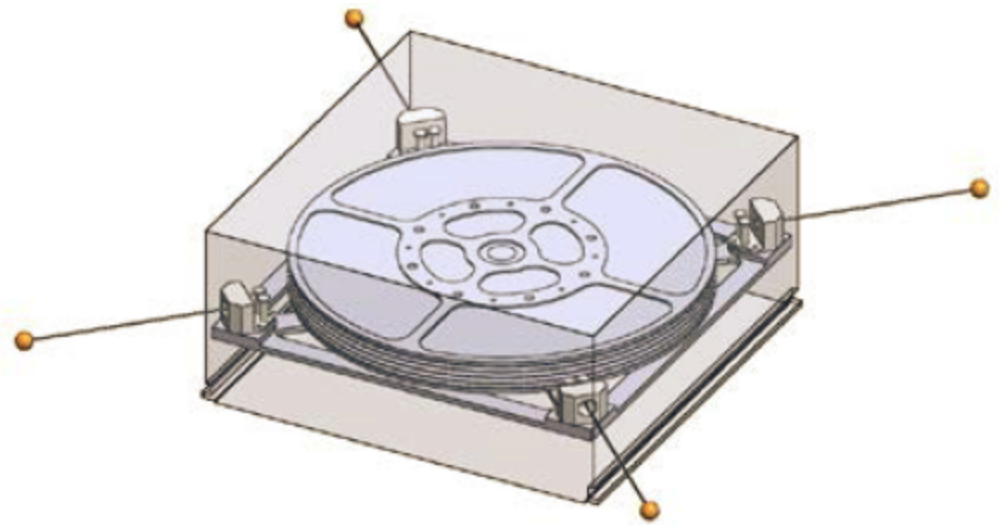
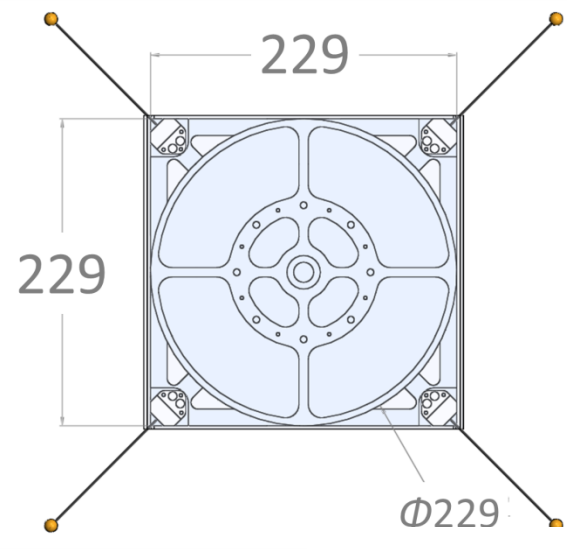

- Major strides have been made in developing hardware infrastructure and instrumentation for science on small payloads.
- DICE was a step in this evolution. It was an ambitious program with two CubeSats, each carrying three space weather instruments. DICE was unable to orient and spin to deploy its cable booms, yet resulted in the development of the most capable radio system to date for CubeSats, enabling data downloads many times faster than existing hardware.
- The mission had many successes, and there were also many lessons learned that were implemented on ASSP and DIME, and the new CLARA instrument



Thank You!

(...or what we will do with “DIMESat” Risk Reduction mission once it’s in space...)

- VxB validation (1 continuous day of data)
- DMSP conjunctions
- ISR + SuperDarn conjunctions (minimum of 3 conjunctions)
- CALVAL is better at high latitudes because of more conjunction opportunities, suggesting that a high inclination orbit is preferred for this technology demonstration mission



- DICE Electric Field Instruments and CubeSats
- Review the challenges and lessons learned from the DICE mission
- Describe the DIME SensorSat, showing how the various challenges are being addressed for DIME, and demonstrating how the new systems will meet its measurement requirements.
- Auroral Spatial Structures Probe
- deployment lengths of 50 meters.

Dynamic Ionospheric Measurement of Electric fields Satellite (DIMEsat)

| Driving Requirement (Goal) | Capability | Margin (Goal) |
|---|---|---|
| E-Field (Satellite Ref Frame) 1. ± 1250 (1250) mV/m range 2. 0.5 (0.15) mV/m sensitivity 3. 3.6 (0.15) mV/m uncertainty 4. DC to 4 (50) Hz bandwidth 5. 4 to 1k (12k) Hz spectrometer 6. 4 (16) spectrometer channels B-field 1. $\pm 60,000$ nT range 2. 5.0 (2.0) nT sensitivity 3. 30.4 (10.2) nT uncertainty 4. DC to 4 (50) Hz bandwidth Plasma Density/Temperature 1. 10^4 (10^3) to 10^7 p/cm ³ range 2. 10^3 (10) p/cm ³ sensitivity 3. DC to 4 (50) Hz bandwidth 4. 500 (300) to 5,000 K | E-Field (Satellite Ref Frame) 1. ± 1625 mV/m range 2. 0.057 mV/m sensitivity 3. 1.96 mV/m uncertainty* 4. DC to 20 Hz bandwidth 5. 20 to 12k Hz spectrometer 6. 16 spectrometer channels B-field 1. $\pm 61,000$ nT range 2. 0.5 nT sensitivity 3. 5 nT uncertainty 4. DC to 20 Hz bandwidth Plasma Density/Temperature 1. 7.3×10^3 to 6.2×10^8 p/cm ³ 2. 73 p/cm ³ sensitivity 3. DC to 20 Hz bandwidth 4. 300 to 5,000 K | E-Field 1. 27% (26%) 2. 908% (202%) 3. 14% (-49%) * 4. 400% (-60%) 5. Meets Goal 6. Meets Goal B-field 1. 2% (2%) 2. 90%(75%) 3. 83%(50%) 4. 400% (-60) Plasma Den./Temp. 1. 27% (-630%) to 6145% 2. 93% (-630) 3. 400% (-60%) 4. Meets Requirements |

*Assuming an attitude uncertainty of 0.40°