



Group of Astrodynamics for the Use of Space Systems

# 12th Annual Summer CubeSat Developers' Workshop Sunday, August 9, 2015

## ***“G.A.U.S.S. Micro Satellites: Experiences and Proposals”***

**Filippo Graziani, Vladislav Solovey, Chantal Cappelletti  
G.A.U.S.S. Srl  
Roma, Italy**



# G.A.U.S.S. Srl:



- ❑ Starting from the **experience** and the enthusiasm grown at the *School of Aerospace Engineering*, some professors, researchers and students decided to continue the tradition of the school founding the limited liable company G.A.U.S.S. Srl, evolving **from a didactical dimension to an innovative company reality**.
- ❑ The **company business** is mainly related to the design and manufacturing of space systems which are also intended as release platforms for CubeSat and PocketQube using the deployers PEPPOD and MRFOD, thus letting begin G.A.U.S.S. to be a launch provider for small satellites.



# *More and more interest in microsatellites*

Group of Astrodynamics for the Use of Space Systems

- ❑ In the last years, **the interest** of University, Private Companies and government agencies **in launching micro-satellites is growing up.** CubeSats or smaller femto-satellite PocketQube.
- ❑ A few years ago this class of satellites were considered only for didactical or for in-orbit test purposes. Recently **they are even more used in constellations** made with **high performance technologies.**

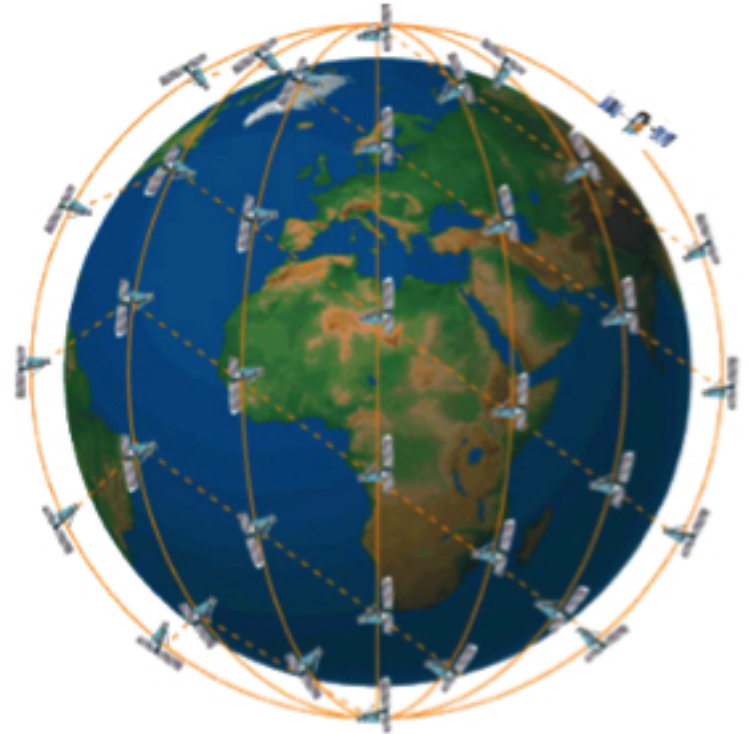

Credit: APL/JHU



Group of Astrodynamics for the Use of Space Systems

# UniSat Satellites as Launcher Platforms:

- ❑ The complexity of the missions for these satellites, **is quickly growing up. There is the need to offer fast, multiple and alternative solutions** to satisfy the customers' goals.
  
- ❑ G.A.U.S.S. Srl has innovated the **idea of launch provider** developing civil and scientific satellites having two primary purposes:
  - acting as **Launch Platforms** to carry and deploy in the Space other smaller satellites;
  - hosting **payloads** on board for scientific missions, testing equipment in space condition, providing power, intelligent control and telecommunication services for the hosted payloads.

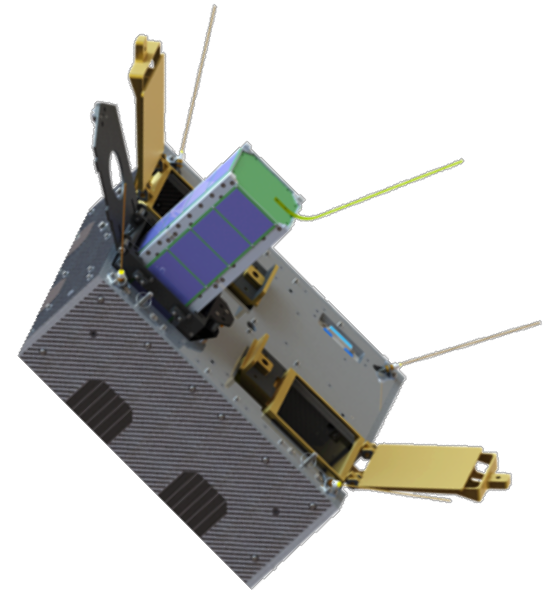



Group of Astrodynamics for the Use of Space Systems

# *UniSat Satellites as Launcher Platforms:*

## ❑ **Some actual advantages:**

- Payloads of the satellites UniSat, are **not** more tied directly to the **scheduled mission of the rocket**.
- It is possible to **avoid the dangerous clouds of satellites** at the separation time.
- More satellites of a **constellation** can be launched on the same cluster launch, but released at **different times**.

## ❑ **Future goals for G.A.U.S.S.:**

Make their platform satellites able to change orbits (**orbital and attitude control**) and release the payloads in a known attitude control status.



# UniSat Satellites:

Group of Astrodynamics for the Use of Space Systems

- ❑ **In less than two years UniSat-5 and UniSat-6 have carried in to space 12 small satellites:**
  - **2013 - UniSat-5** has released 7 satellites using 2 PEPPOD and 3 MRFOD deployers. **It has been the first Spacecraft that has carried in to space the new standard of femto-satellites, the PocketQube.**
  - **2014 - UniSat-6** has released 4 CubeSats using 2 PPOD deployers from CalPoly and 1 PEPPOD. One of the Cubesats has also split in 2 half units.

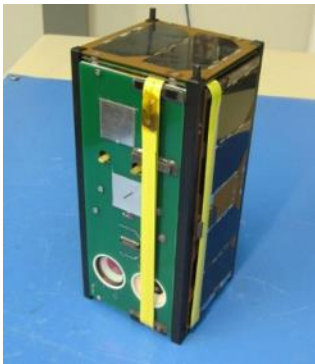

AntelSat (2U)



Lemur-1 (3U)

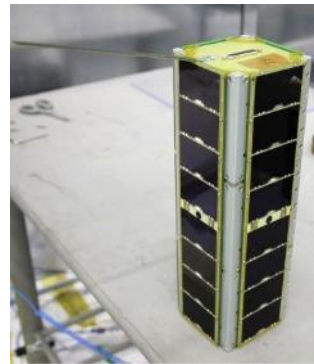

TigriSat (3U)



AeroCube-6 (two 1/2U)



Group of Astrodynamics for the Use of Space Systems

# Launch Service Collaboration: DNEPR LV



- ❑ **Since the year 2000**, G.A.U.S.S. has launched satellites with the support of the **International Space Company (ISC) Kosmotras**.
- ❑ Taking advantages of this fruitful cooperation, G.A.U.S.S. Srl is actually able to offer **launch services** for microsatellites in general.
- ❑ **Reliability:** currently, the mission reliability factor for the rocket is 0.97

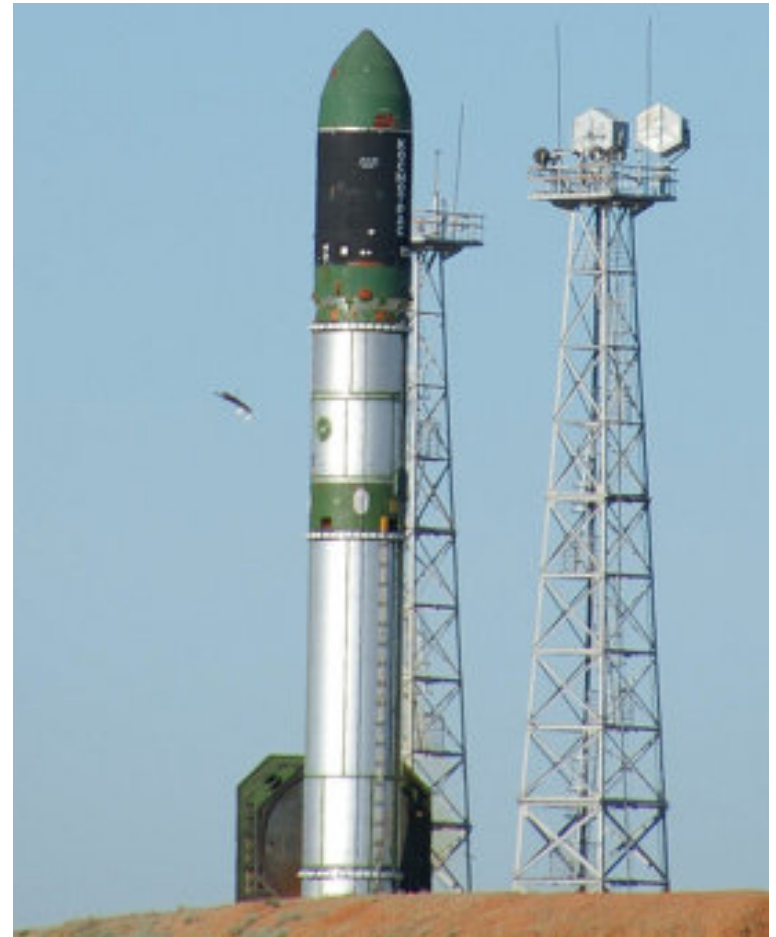



# UniSat-6 Mission:

Group of Astrodynamics for the Use of Space Systems

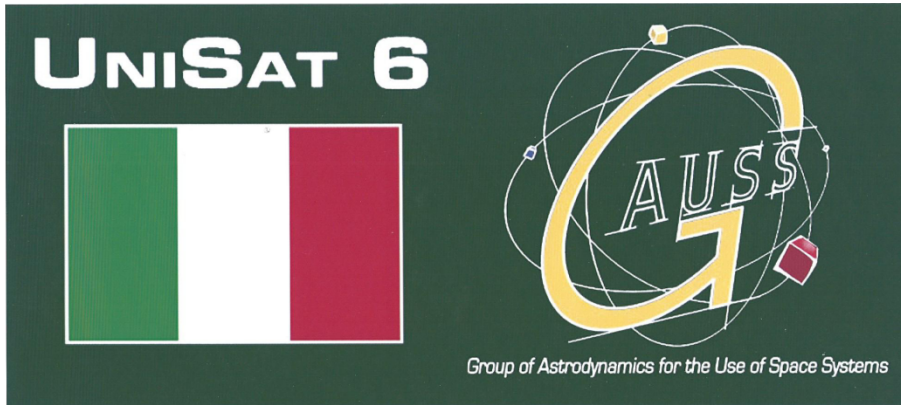





# UniSat-6 Mission:

Group of Astrodynamics for the Use of Space Systems

- ❑ It was launched in June 19<sup>th</sup> 2014 from Dombarovsky Cosmodrome at Yasny (Russia).
- ❑ Cluster Mission of 32 satellites (37 considering the UniSat-6's payloads).





# UniSat-6 Mission:

Group of Astrodynamics for the Use of Space Systems

Name	Class	Mission Purpose	Ownership	Country
UniSat-6	NanoSatellite	Educational Deployer of Cubesat using PPOD and Peppod <b>No military purpose</b>	GAUSS Srl	Italy
TigriSat	3U CubeSat	Deployed from UniSat-6 University student education <b>No military purpose</b>	University of Rome, Sapienza	Italy
AeroCube6	1U CubeSat	Deployed from UniSat-6 Reserch and Development <b>No military purpose</b>	CalPoly	USA
ANTELSAT	2U CubeSat	Deployed from UniSat-6 Educational <b>No military purpose</b>	Universidad de la Republica (UdelaR)	Uruguay
Lemur-1	3U CubeSat	Deployed from UniSat-6 Reserch and Development <b>No military purpose</b>	CalPoly	USA



# UniSat-6: Deployment System

UniSat-6

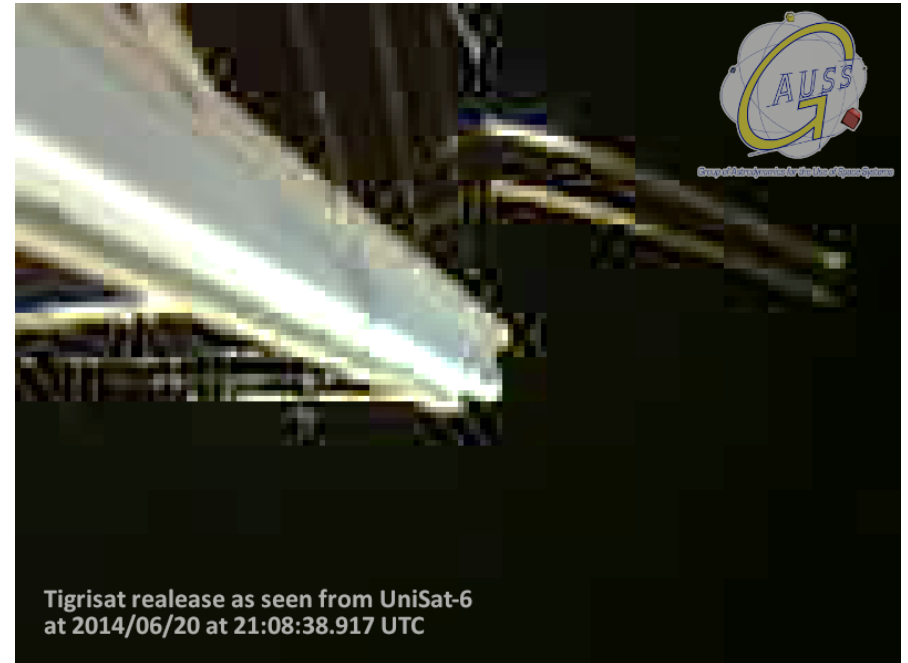
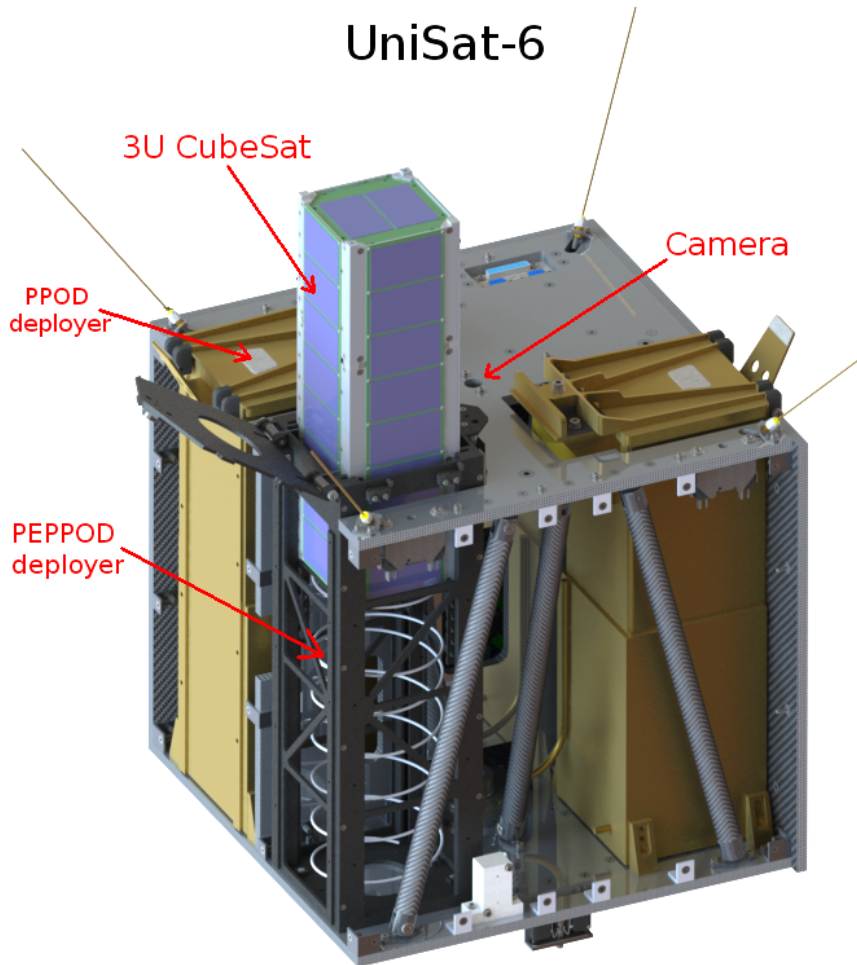

## Orbital Deployers:

- 1x PEPPOD (G.A.U.S.S. Srl)
- 2x PPOD (CalPoly)



Group of Astrodynamics for the Use of Space Systems

# UniSat-6: PEPPOD Deployer

- ❑ It is **lighter** than other Orbital Deployers, it is well suitable to be installed on Spacecrafts.
- ❑ It was designed by G.A.U.S.S. Srl to be used with 1U, 2U and 3U CubeSats, it is also **customizable on request**.
- ❑ It uses the high reliable and space qualified **FRANGIBOLT** opening system (TiNi-Aerospace).
- ❑ It was **used with success** on UniSat-5.





Group of Astrodynamics for the Use of Space Systems

# UniSat-6: Deployment Strategy

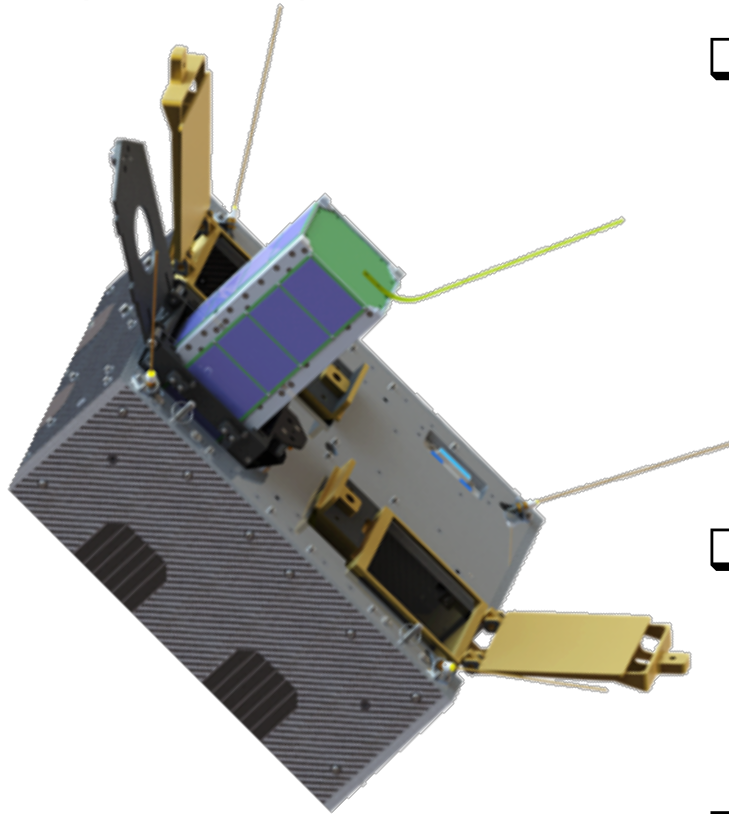

- ❑ **Primary automatic release system:**
  - completely autonomous
  - redundant activations
  - hardwired logic (no microcontrollers)
  - dedicated battery pack
  
- ❑ **Release Time of CubeSats:** 25h 38' after the separation of UniSat-6 from the Dnepr LV, following a precise scheduling
  
- ❑ **Secondary redundant release system:** by TT&C it is possible to override the automatic system to open the PODs



# UniSat-6: the satellite

Group of Astrodynamics for the Use of Space Systems

## ❑ Orbital parameters:

- quasi sun synchronous orbit
- Around 700km height
- period of revolution 5878s
- orbit inclination 97,98°

## ❑ Shape: A cube of 40cm side by side

## ❑ Weigh: 26 Kg with payloads inside

## ❑ Attitude control: passive with permanent magnet and histeresys rods

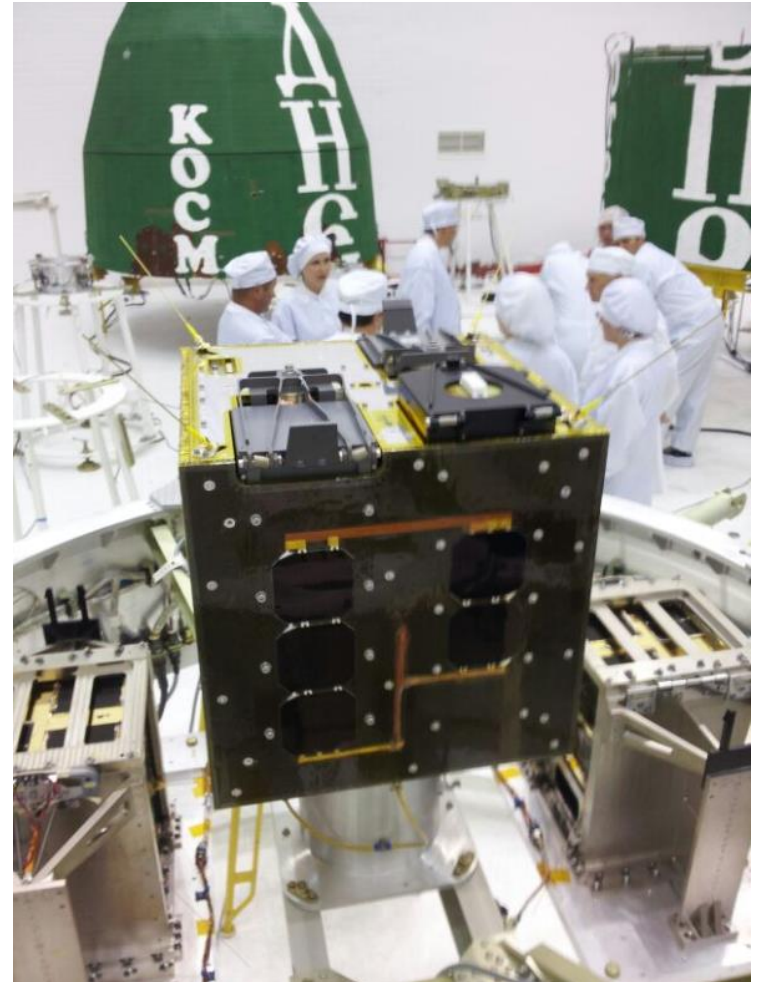



# UniSat-6: Ground Segment & communications

Group of Astrodynamics for the Use of Space Systems

❑ UniSat-6 is clearly received at very low elevation (about  $1^\circ$ ) by ground stations.

❑ It is also possible to receive the telemetry by **radio-amateur** handsets without any modifications.

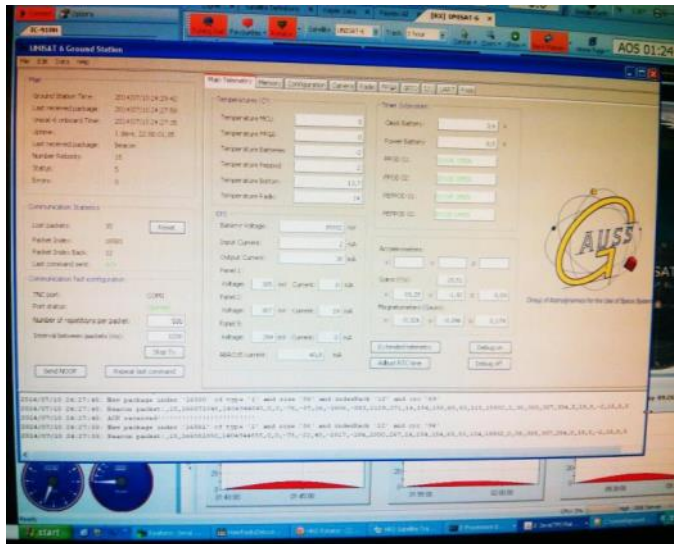

❑ A **Dedicated software** has been developed by **G.A.U.S.S. Srl** for uplink and downlink operations.

❑ Since the first day in orbit, up to 5 passes per day have been followed over Rome, downloading stored telemetry and pictures.



# UniSat-6: Sub Systems

Group of Astrodynamics for the Use of Space Systems

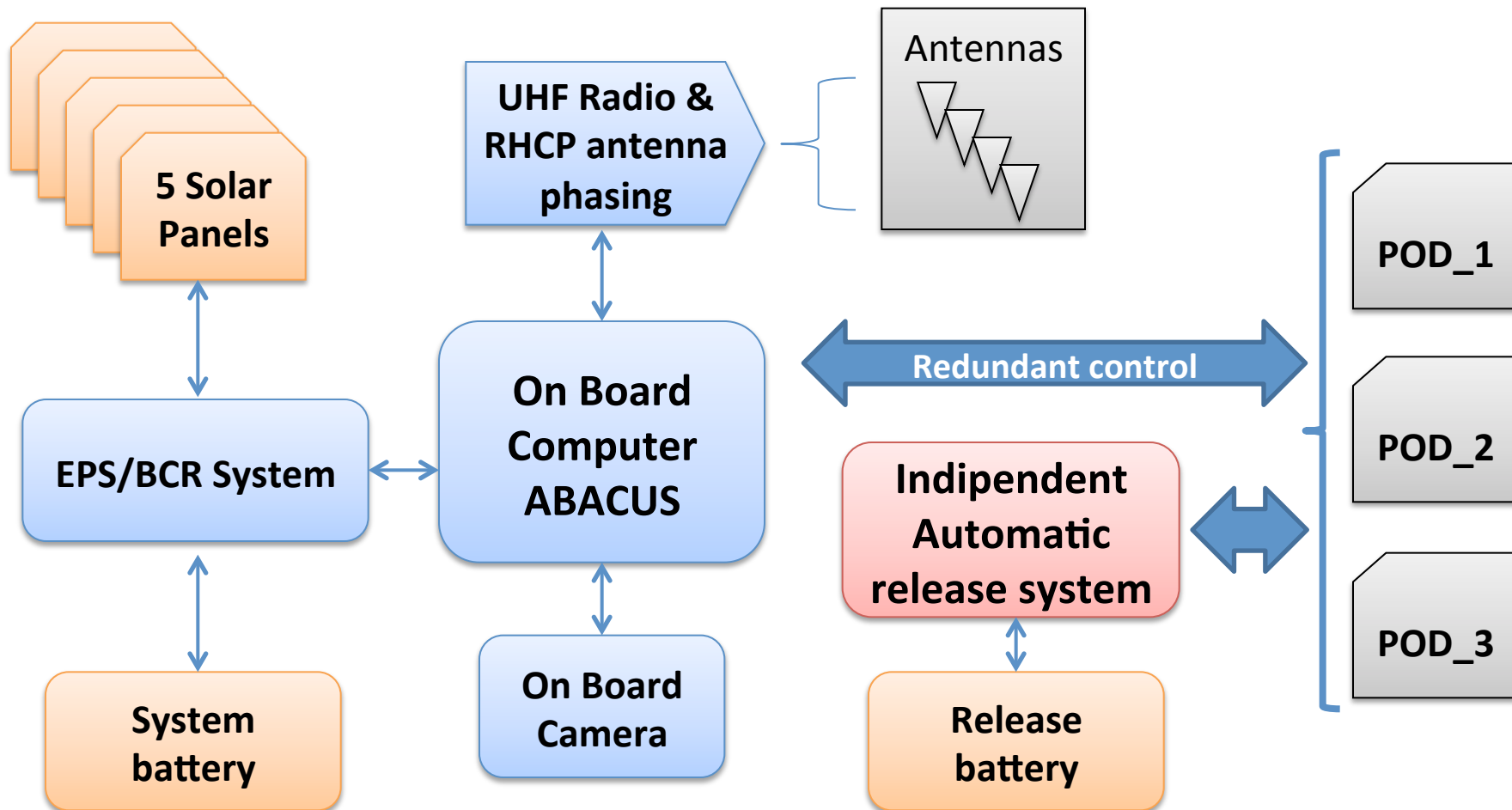





# UniSat-6: Sub Systems

Group of Astrodynamics for the Use of Space Systems

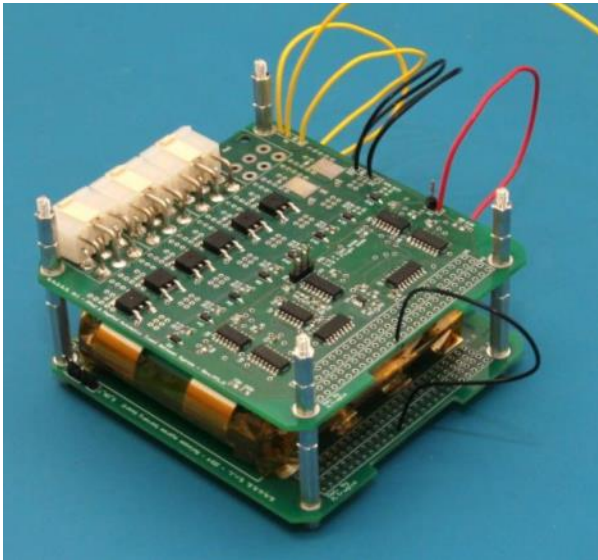

Automatic Timed Release System  
for PPOD and PEPPOD deployers  
(**G.A.U.S.S. Srl**)

ABACUS On Board Computer  
(**G.A.U.S.S. Srl** and "Sapienza"  
University of Rome)

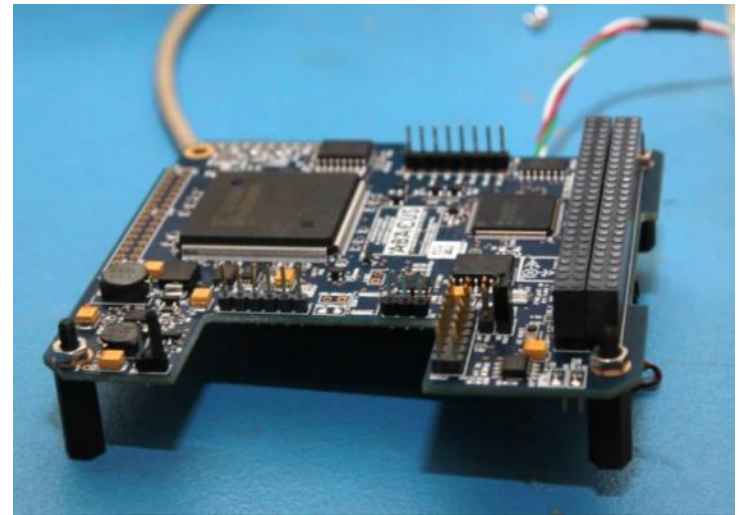



# UniSat-6: Sub Systems

Group of Astrodynamics for the Use of Space Systems

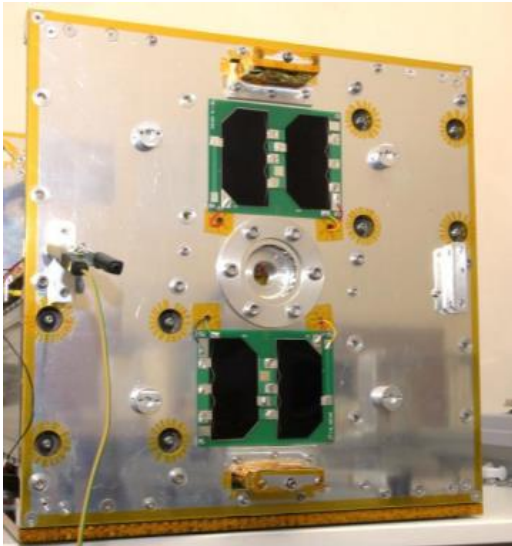

Bottom Solar Panel  
Power 5W  
(G.A.U.S.S. Srl)

On Board Camera  
3 Mpx Jpeg  
(LinkSprite)

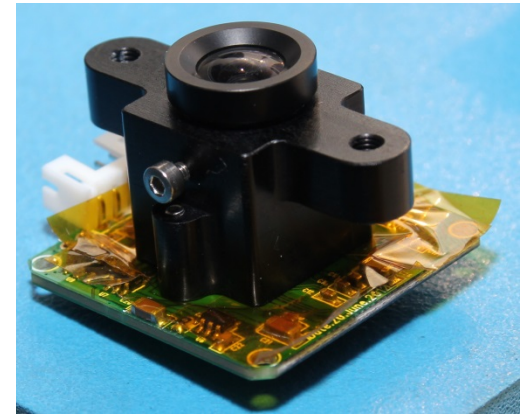



# *UniSat-6: the Point of View from the Space*

Group of Astrodynamics for the Use of Space Systems

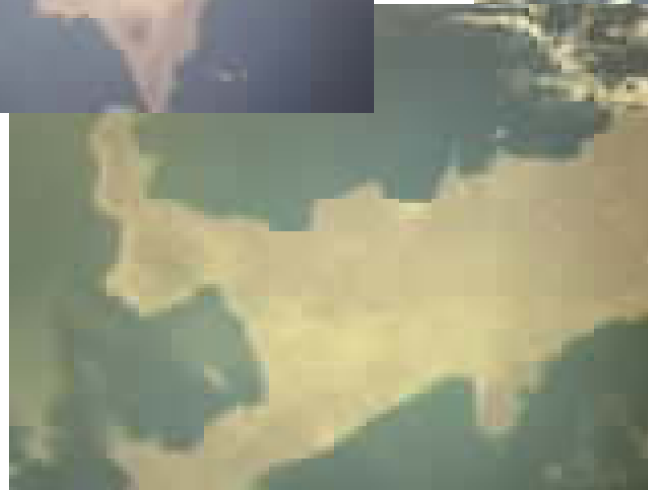

❑ Some pictures in low resolution (for video) in a pass over Italy



# *UniSat-6: the Point of View from the Space*

Group of Astrodynamics for the Use of Space Systems

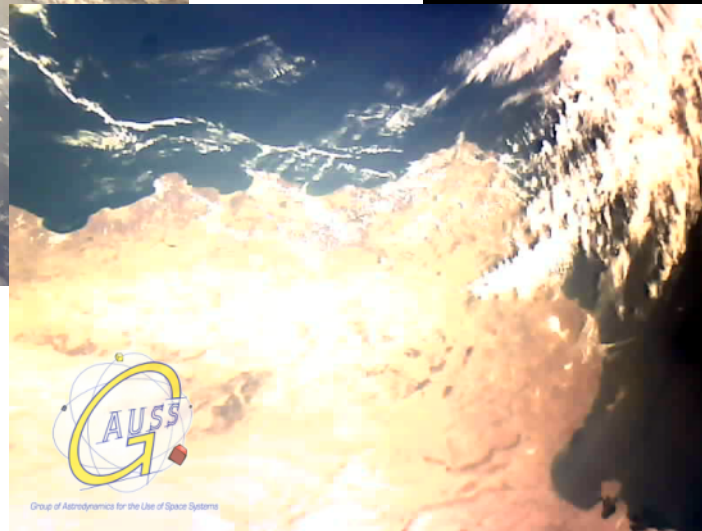
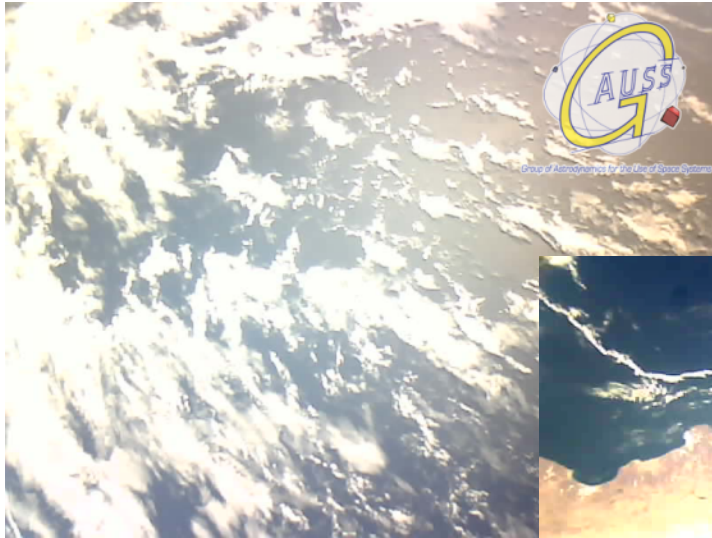

❑ Mid resolution pictures: clouds on Madagascar, Tunisia and Earth view



# UniSat-6: the Point of View from the Space

Group of Astrodynamics for the Use of Space Systems

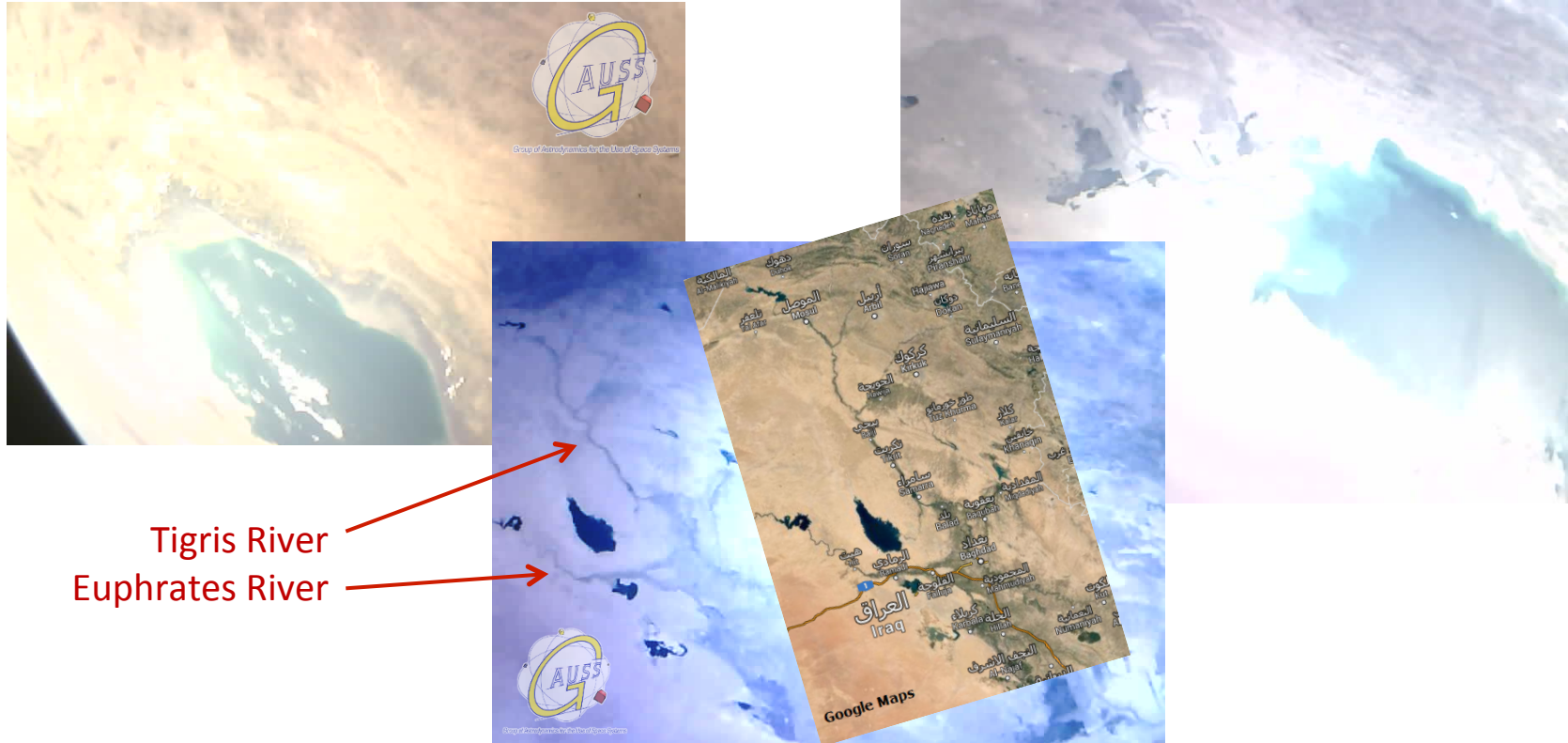

Tigris River  
Euphrates River

❑ Mid resolution pictures: Caspian Sea, Iraq and Persian Gulf



# *UniSat-6: the Point of View from the Space*

Group of Astrodynamics for the Use of Space Systems

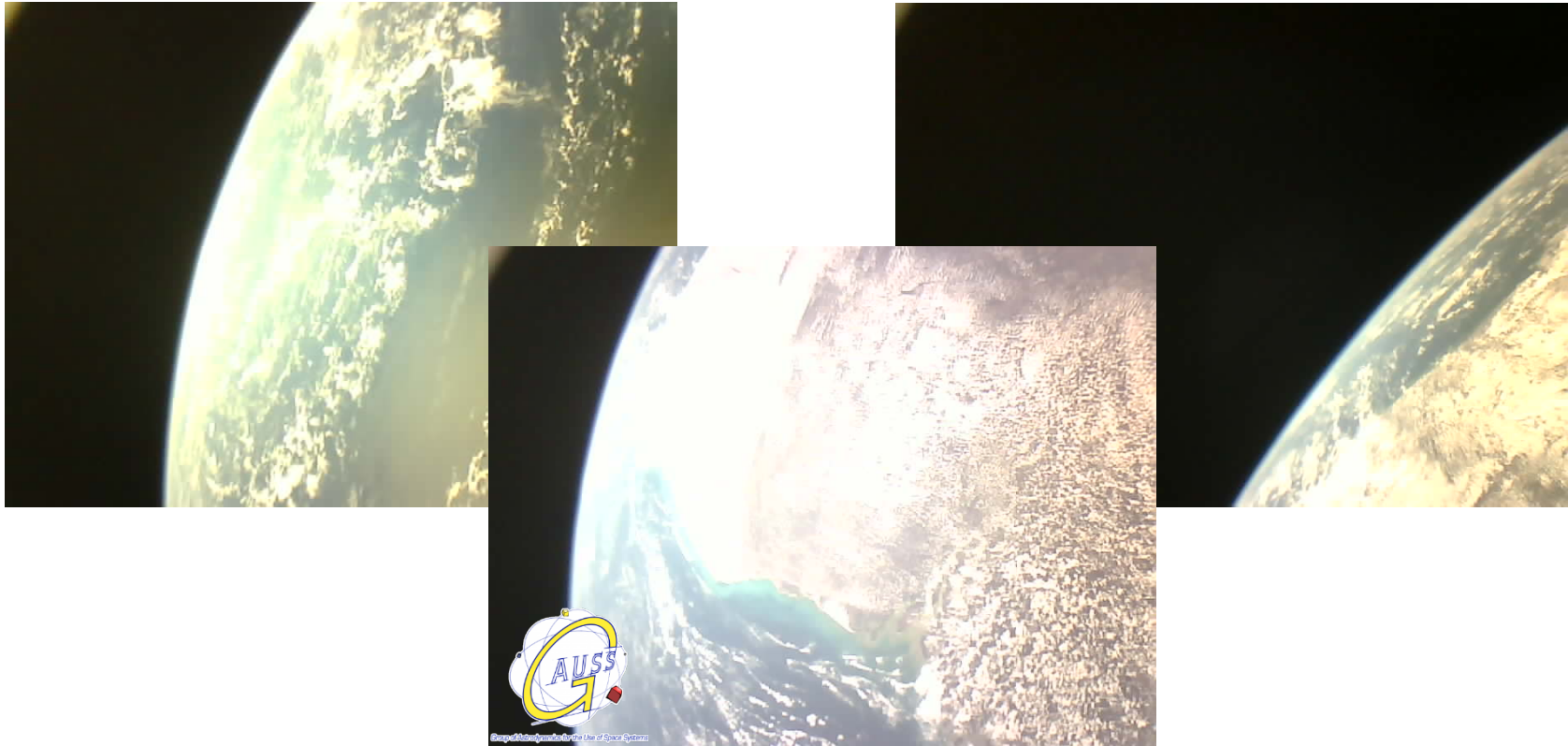

☐ Mid resolution pictures: clouds on Brazil



# UniSat-6: Integration time

Group of Astrodynamics for the Use of Space Systems

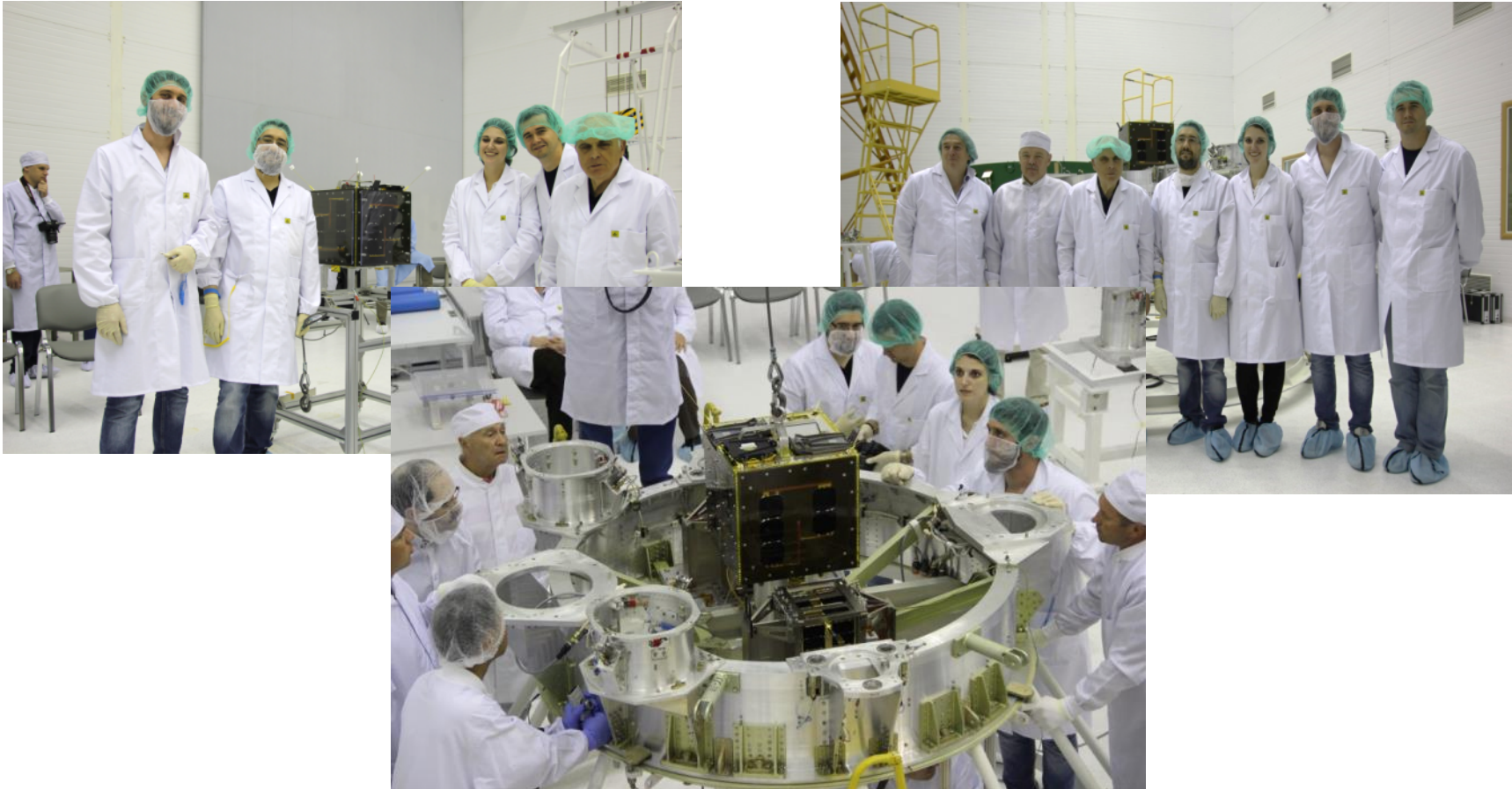

In the pictures: P. Teofilatto - V. Kainov - F. Graziani - M. Truglio - C. Massimiani - S. Paiano - A. Conde Rodriguez



# ***Towards UniSat-7..... from the past to the future***

Group of Astrodynamics for the Use of Space Systems







# Towards UniSat-7: On-Going Projects

Group of Astrodynamics for the Use of Space Systems

## ❑ Structure:

- G-POD
- Q-POD
- PentaPOD

## ❑ Attitude Control:

- Magnetic Torquers
- Reaction Wheels

## ❑ Electric Propulsion:

- Pulsed Plasma Thruster (PPT)

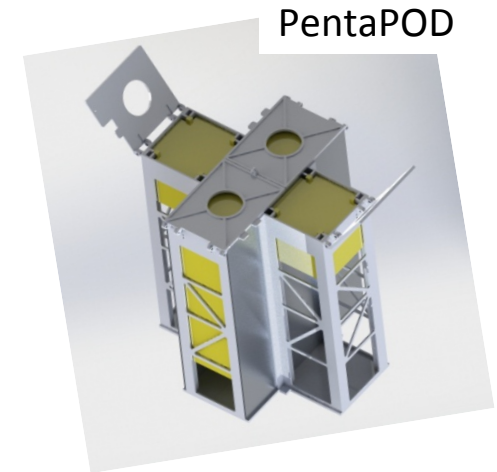
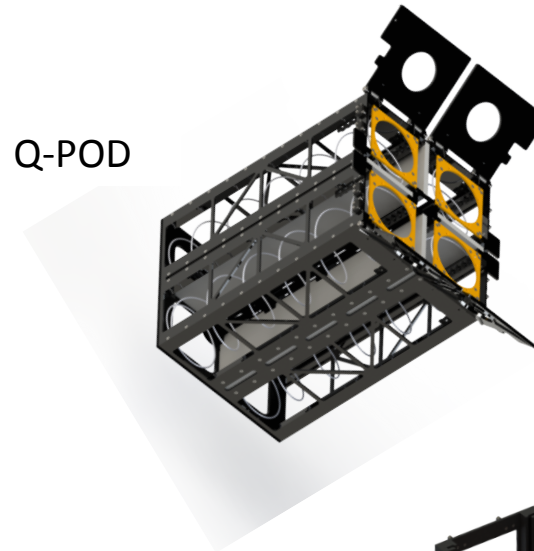



Group of Astrodynamics for the Use of Space Systems

# Proposals: the Point of View from the Earth



credits Aitor Conde

□ Picture of UNISAT-6 as seen over Bilbao (Spain)



Group of Astrodynamics for the Use of Space Systems

# *Proposals: the Point of View from the Earth*

- ❑ **Space Debris Observations:**  
**From the Earth** - the Castelgrande Observatory is an optical space debris observation center in Italy.



Castelgrande Observatory (Italy)



# Proposals: the Point of View from the Space

Group of Astrodynamics for the Use of Space Systems

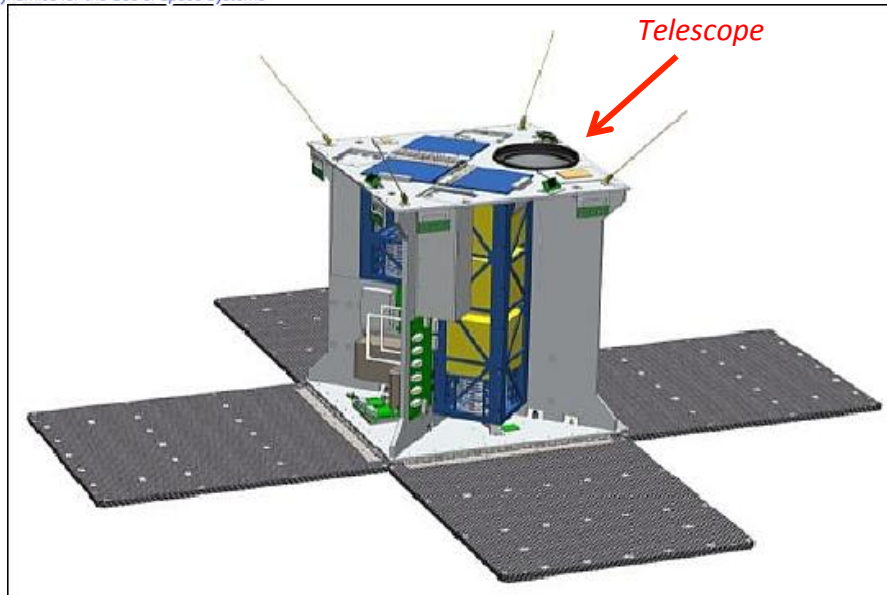

- ❑ **Space Debris Observations: From the Space** – the proposal is to use a telescope on board of a satellite

- ❑ **Deorbiting Systems:**

- **Sirdaria Sail**, a deployable sail with the purpose of increasing the aerodynamic drag reducing satellite mechanical lifetime.
- **Propulsion**

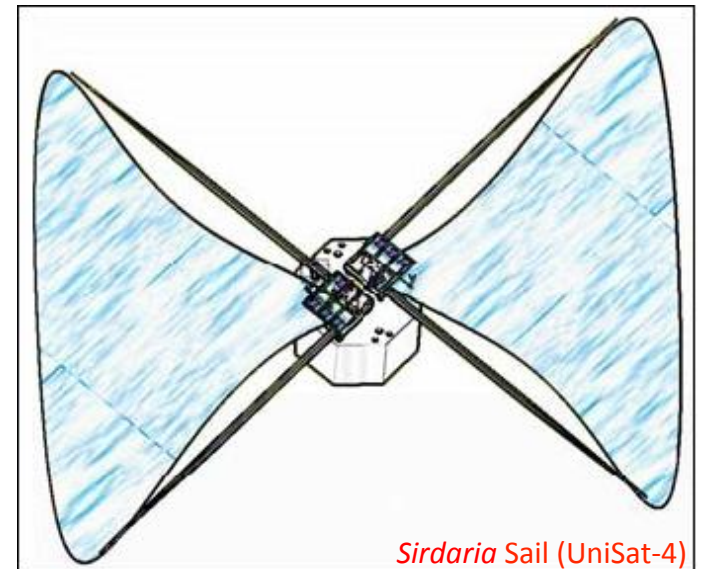

*Sirdaria Sail (UniSat-4)*



# *Thanks to...*

Group of Astrodynamics for the Use of Space Systems

