

# ***Lessons learned measuring 3U and 6U payload rotation and velocity when dispensed in reduced gravity environment***

Floyd Azure, Ryan Hevner and Walter Holemans of Planetary Systems Corporation (PSC)

2303 Kansas Avenue  
Silver Spring, MD 20910  
301 495 0737



*Ellington Field, TX  
August 2014*

- Flight test objective
  - Measure rotation rates and velocity of 3U and 6U payloads as a function of dispensing from Canisterized Satellite Dispenser (CSD)
    - Vary payload mass and separation spring energy
- Four days of flight testing
  - 40 parabolas per day
  - 136 dispensing events in 160 parabolic opportunities
- Ellington Field, TX / Gulf of Mexico
- Sponsored by NASA, AFRL and PSC

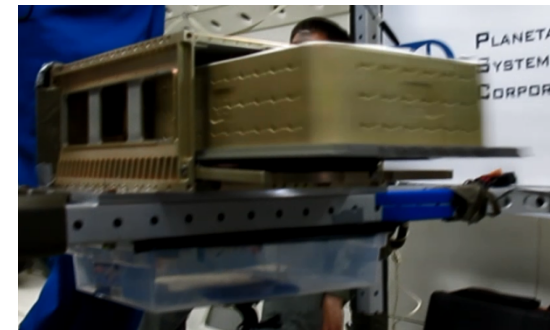
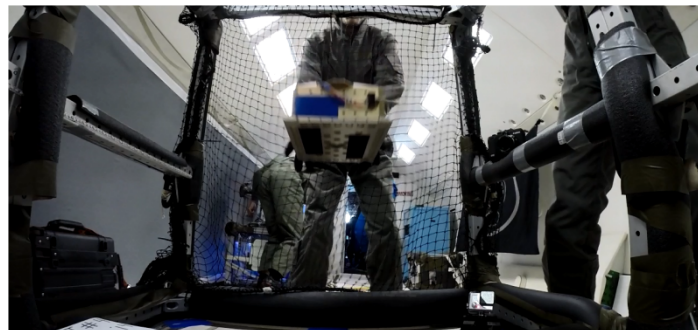

(Show Video)

# What is a Canisterized Satellite Dispenser (CSD)?

- A box that holds a spacecraft for launch and dispenses on orbit

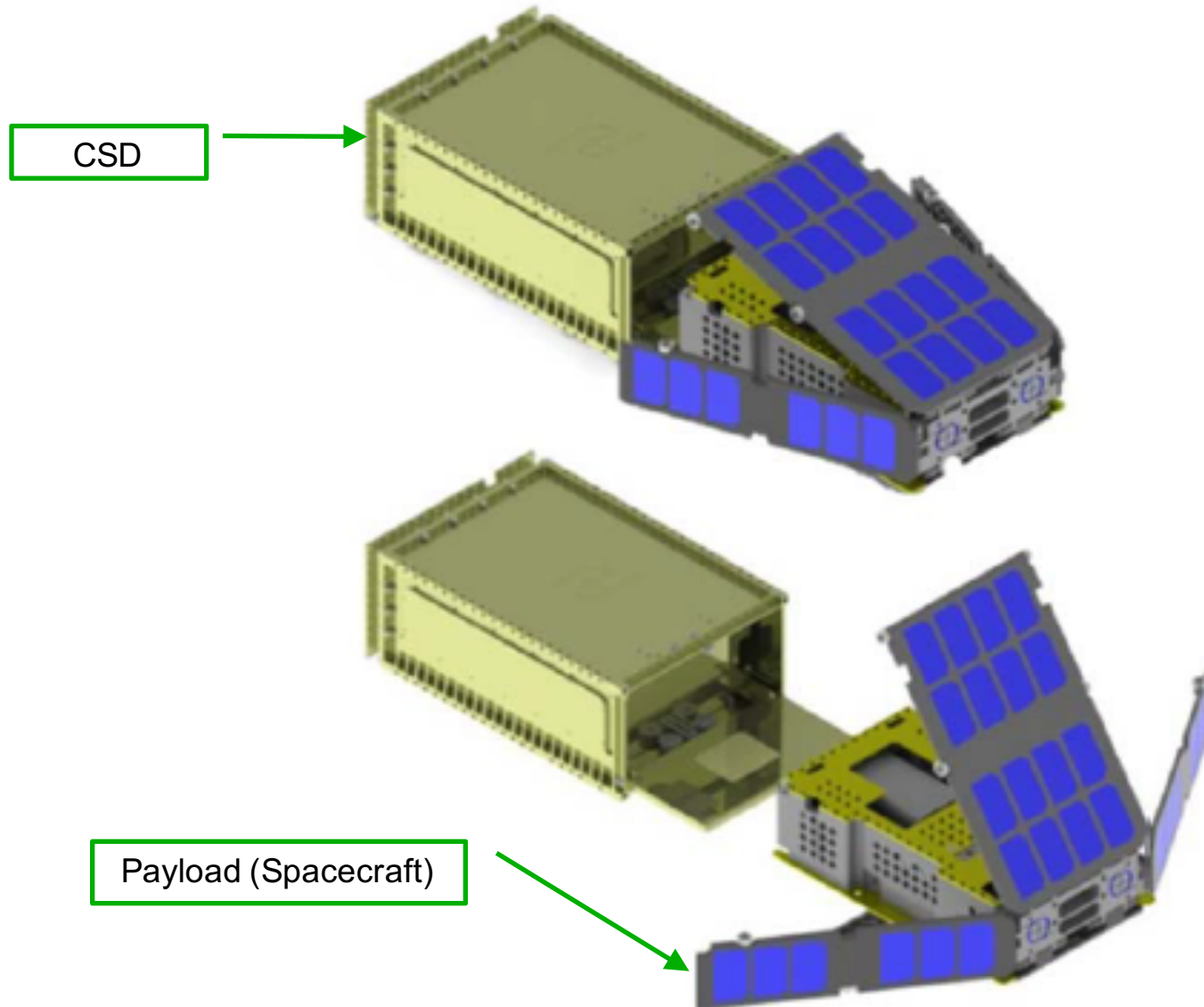

# Test Equipment

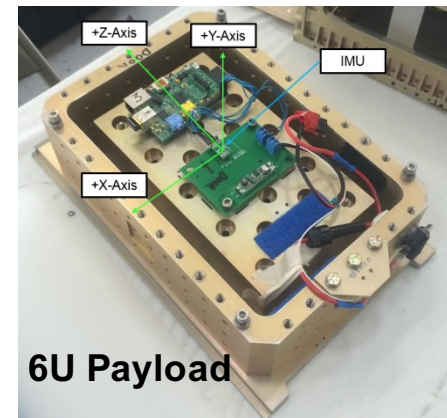
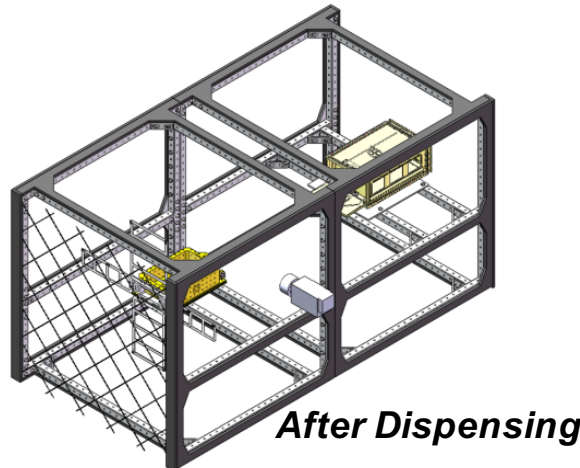
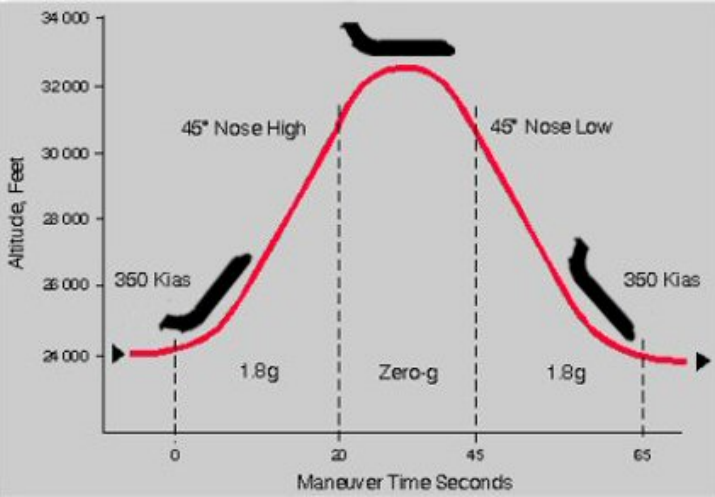
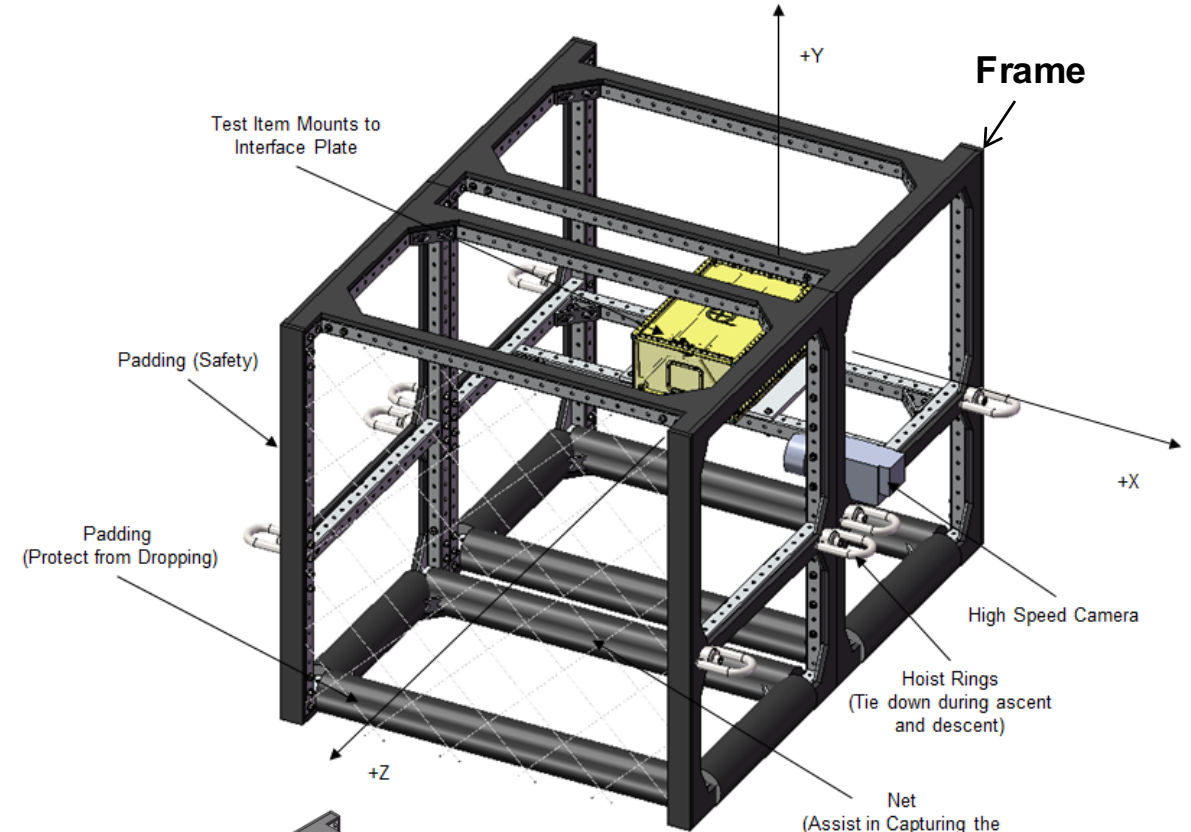



- Schematic

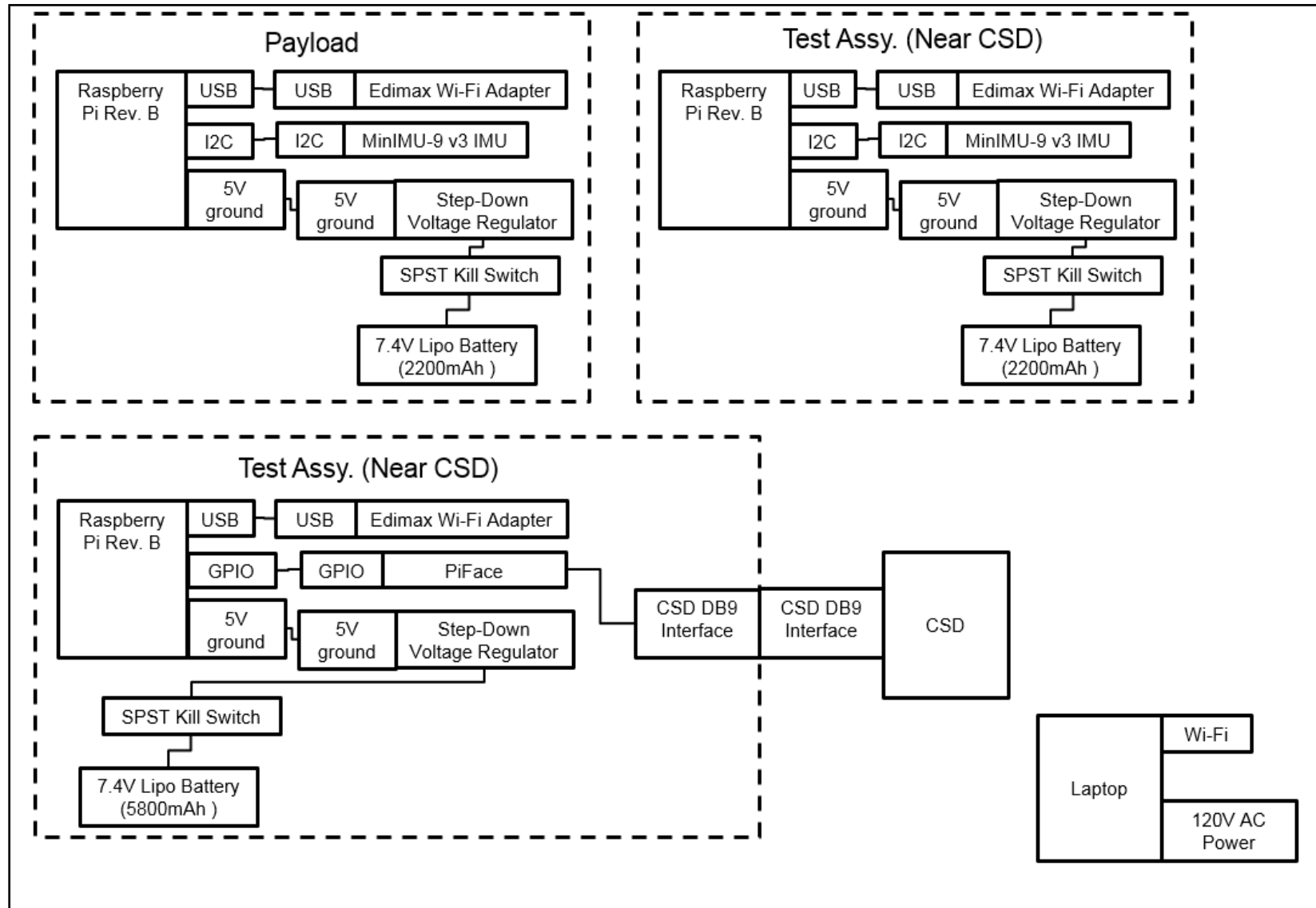

## Why Test?

- Failure to dispense upon command ('Hang-fire') and dispensing when not commanded ('Auto-actuate') are known, recurring failure modes
  - P-POD, Dec 2010
    - Hang-fire (ref 1)
  - NanoRacks CubeSat Deployer (NRCSD), August 2014, ISS
    - Hang-fire (ref 2)
- Predictable rotation and velocity rates are essential in bounding the initial conditions of CubeSat spacecraft so engineers can size the attitude control system (ref 3) and predict time to establish satellite constellations
- Cubesats, in general, have an on-orbit failure rate ~50% (ref 9)

**Answer:** To uncover failure modes and performance deficiencies...before launch

# For each dispensing event we acquired acceleration and rotation

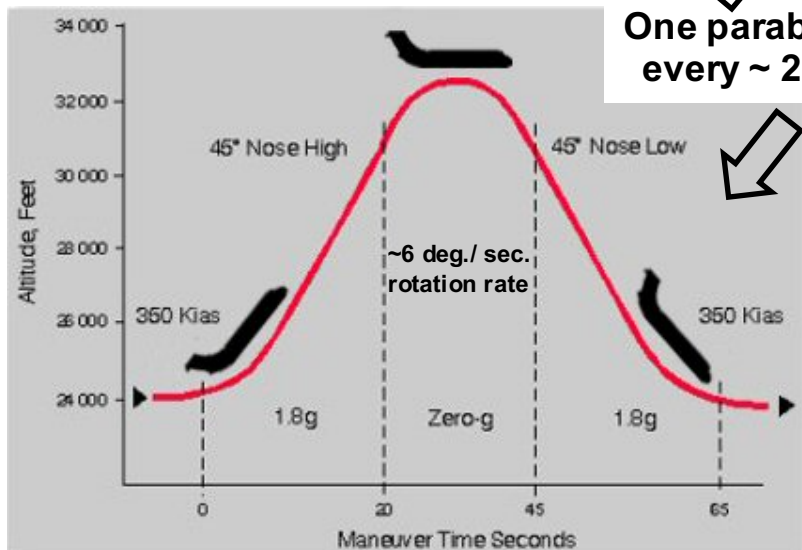
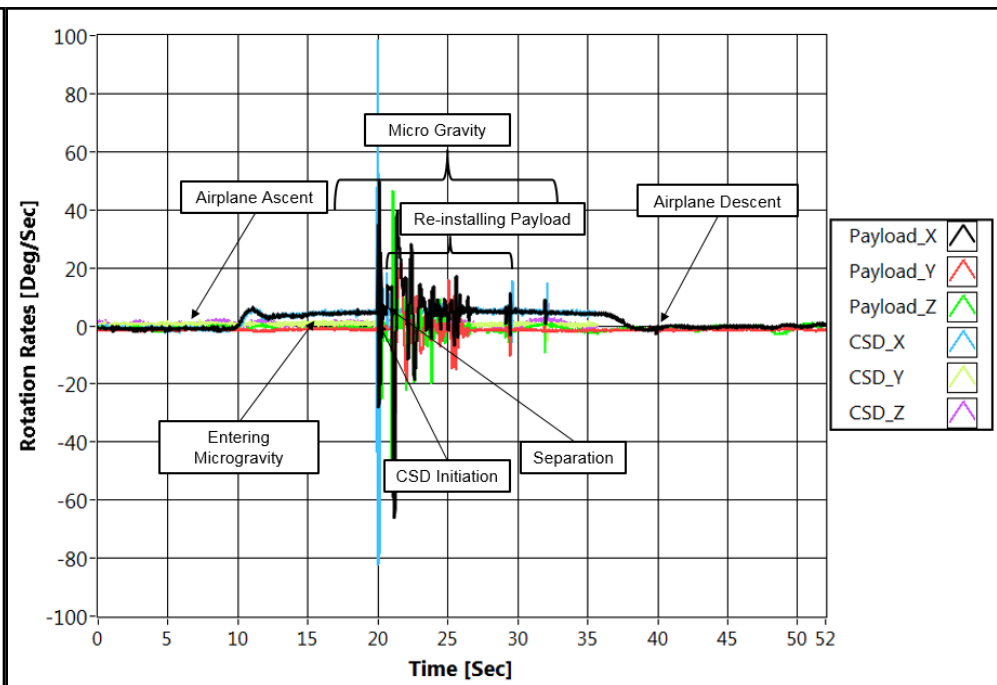
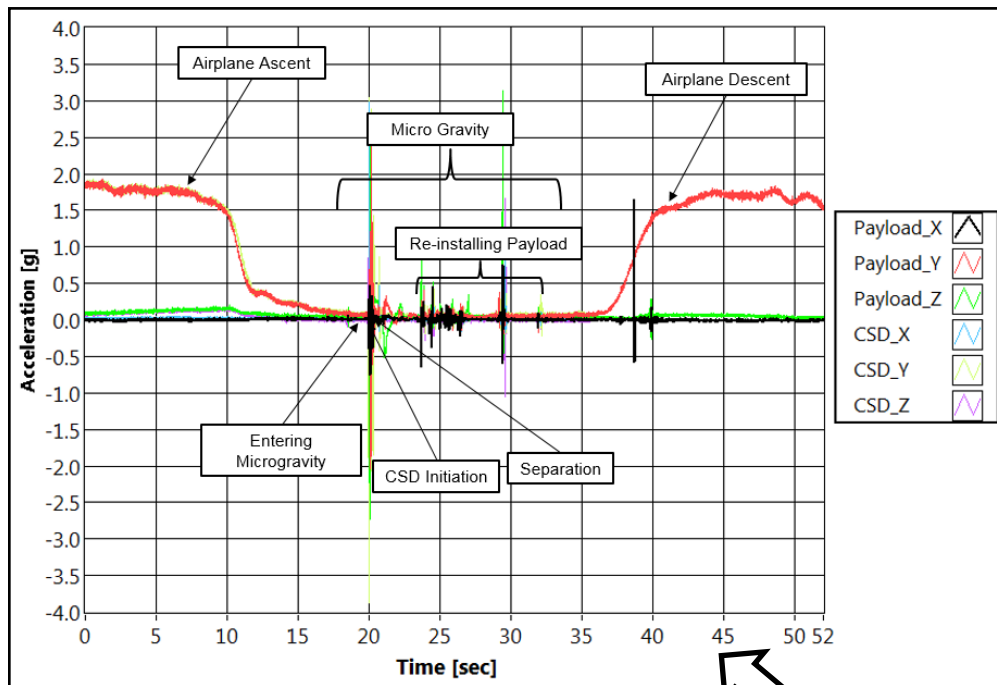

One parabolic cycle every ~ 2 minutes

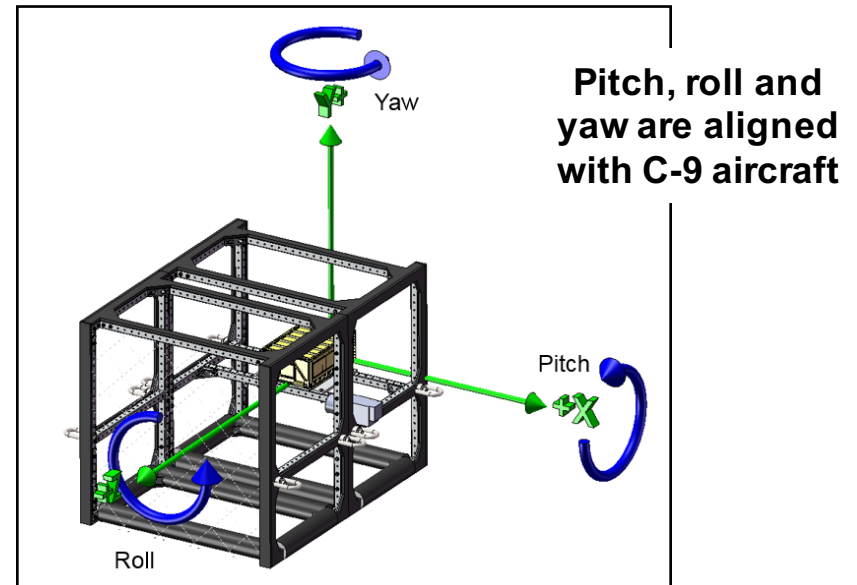

Pitch, roll and yaw are aligned with C-9 aircraft

# Rotation Summary

- Higher initial rates (from aircraft rotation) produce higher rates after dispensing
- CSD dispenses payloads one to two orders of magnitude lower rotation rate than other dispensers (ref 3 and 4)
- CSD reliably dispenses when initial rates are  $\sim 10x$  higher than on orbit

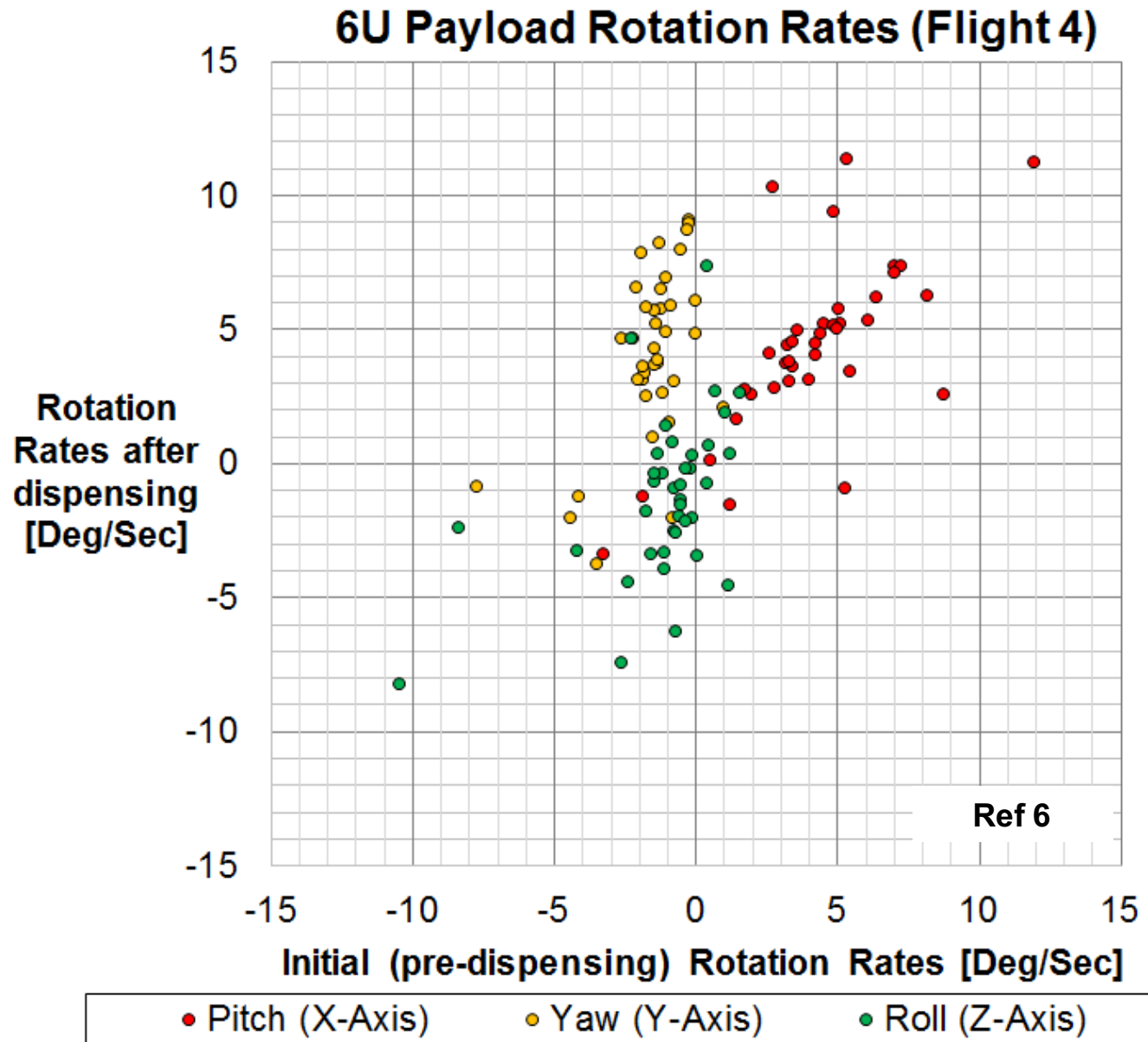



# Separation Velocity was not usefully acquired

- Sources of error
  - Initial rotation rates and vibration from door opening transient cause oscillating friction as payload is dispensed
    - Payload can jiggle as it comes out
    - Frame is not stiff enough / underdamped
  - Bias and bias drift of accelerometer creates unbelievable results:

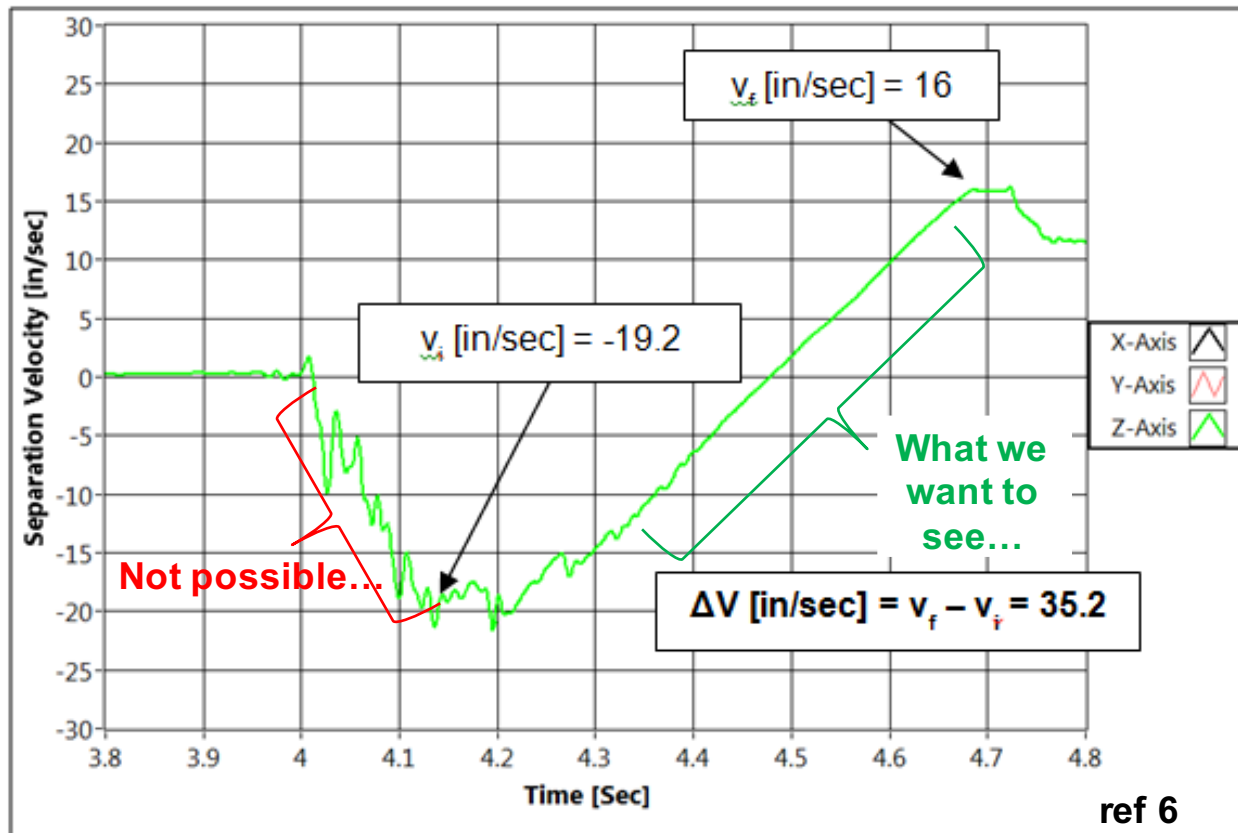

# Approximate Cost and Schedule

- NASA has programs where the entire flight service is 'free'
- Labor and materials for the experiment are not subsidized
- Cost of flight services is based on commercially informed estimates (ref 8)

TASK	Engineer Labor [Hours]				Non Labor Costs [\$]				Schedule [Months]					Remark	
	1	2	3	4	Travel	Materials	Shipping	Flight Services	1	2	3	4	5		
Experiment Design	24	120	40	40					X	X					
Experiment Fabrication	8	40	40	8		18,000					X				
Flight safety	8	16	16	8							X				
Flight test	60	60	60	60	8,000		4,000	235,200				X			Four persons, four days, 40 parabolas/day
Report	16	40	8	8		500							X		
Publication	8	16	16		2,000								X		
<b>Total labor [Hours]</b>	<b>720</b>														
<b>Labor [\$]</b>	<b>108,000</b>														
<b>Non Labor [\$]</b>	<b>294,470</b>														
<b>Total [\$]</b>	<b>402,470</b>														
<b>Total (if flight is 'free') [\$]</b>	<b>143,750</b>														
Max per dispensing event [\$/event]	2,515														
Min. per dispensing event [\$/event]	898														

- Aircraft induces rates of rotation ( $\sim 6$  deg/sec) not present in space flight
  - Reaction wheels/CMG can be used to null pre-dispensing rates of Frame
- If structure supporting dispenser is not stiff ( $>35$  hz) or high damping, the door-opening produces transients that
  - Increase standard deviation of velocity
  - Blur images meant to capture dynamics
  - Applies on-orbit
- Accelerometer bias and bias drift create substantial error in velocity calculation
  - May be more cost effective to procure UAV grade IMU's ( $\sim \$5K$ ) instead of COTS ( $\sim \$50$ )
  - If aircraft's more capable IMU can broadcast its inertial rates real time, then COTS IMU's bias drift may be correctible in situ and so be acceptable
- First flight (of four) included a lot of tuning and acclimating
  - Not all of the 160 available parabolas were used because we were newbies
- Center of mass (CM) offsets from center of ejection force may produce tip-off rates (proportionately)

- For CSD, tip-off rates are  $<10$  deg./sec. when initial rates are zero
  - Separation velocity measurement has too many test induced errors
    - Better IMUs, frame and attitude control system needed
- Total cost is \$402K for 160 parabolas
  - Must have a dispenser that can be reset in 30 seconds to take advantage of 2 minute parabola rate
  - Takes 5 months to complete test program
- May take more than one flight campaign to attain all data
- Remarkable experience!

1. <http://www.nasa.gov/centers/marshall/news/news/releases/2011/11-009.html>
2. <http://spacenews.com/astronauts-repair-space-station-satellite-deployer>
3. Stefano Rossi, Anton Ivanov, Muriel Richard, Volker Gass, Amin Roesch, **Four years (almost) of SwissCube operations** SwissCube Team, Swiss Space Center, Small Sat pre-Conference Workshop, Logan UT, August 10, 2013
4. **NanoRacks CubeSat Deployer Program-1 releasing satellites from the ISS**, <https://www.youtube.com/watch?v=JQy9EwMrILI>, 05 March 2014
5. Azure, Floyd. **2002655A AS RUN SBIR 3U CSD Micro-g Test Plan**, PSC, Silver Spring MD, Sept 2014
6. Azure, Floyd. **2002657A AS RUN SBIR 6U CSD Micro-G Test Plan**, PSC, Silver Spring MD, Sept 2014
7. Hevner, Ryan **CANISTERIZED SATELLITE DISPENSER (CSD) DATA SHEET**, PSC, Silver Spring MD, 21 July 2014
8. [http://www.gozerog.com/index.cfm?fuseaction=Research\\_Programs.welcome](http://www.gozerog.com/index.cfm?fuseaction=Research_Programs.welcome)
9. <https://sites.google.com/a/slu.edu/swartwout/home/cubesat-database>



# Acknowledgements

---

- Special thanks to Hand-Peter Dumm, AFRL and NASA