

Blue Canyon Technologies

XB1

Enabling a New Realm of CubeSat Science

George Stafford BCT

*720.458.0703
1600 Range St, Suite 200
Boulder, CO 80301*

About BCT



Blue Canyon Technologies is a small business founded in 2008 by industry veterans who have developed, tested and flown components and systems on more than 27 diverse space missions

Advancing the state of the art in affordable space access

Current customers include: DoD agencies, Commercial, and Universities

BCT Products



- **Reaction Wheels** – Nano, CubeSat, and Micro-Sat sized Wheels (RW030, RW150, Micro-RW)
- **CARBON ST** - CubeSat Compatible Micro-Star Tracker
- **XACT** - Complete CubeSat GN&C System (1/2U with Precision 3-Axis Pointing)
- **XB1** - Precision Pointing XACT Based CubeSat Bus (*Available 2013*)

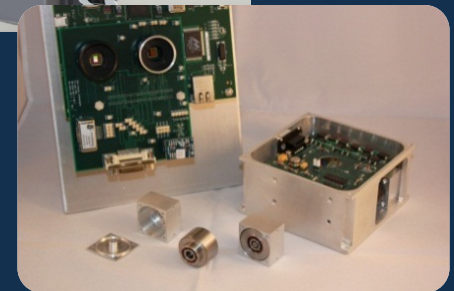
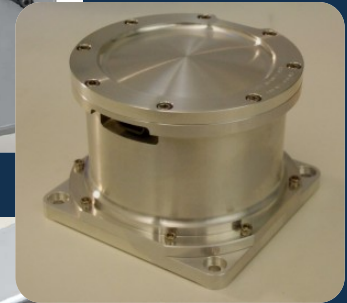

XACT



High Performance Attitude Control for CubeSats

- **XACT micro-Star Tracker** and **micro-Reaction Wheels** enable precise 3-axis control in any attitude
- **Highly-integrated** architecture in a powerful processing core
- Low recurring cost and lead time
- Flight units being designed, built, and qualified under a contract to AFRL

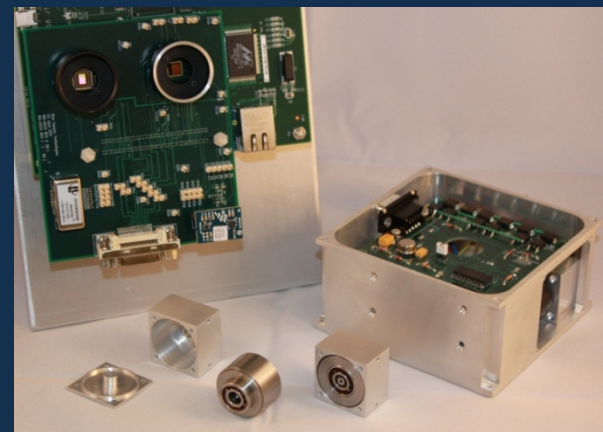

Specification	XACT Performance
Spacecraft Pointing Accuracy	± 0.02 deg (3-sigma) for all 3-axis
Spacecraft Lifetime	≥ 1 Year
Spacecraft Orbit Altitude	LEO (160 - 2,000 km)
XACT Mass	≤ 0.7 kg
XACT Volume	$\leq 10 \times 10 \times 5$ cm (0.5U)
XACT Nominal Power Consumption	≤ 0.5 W
XACT Peak Power Consumption	≤ 2.0 W
XACT Operating Voltage	12 +/- 2V
Data Interface	RS-422 (can support I2C and SPI)
Slew Rate (8kg, 3U CubeSat)	≥ 10 deg/sec

- **3-axis** Stellar Attitude Determination
- **½ U Micro-package**
- **Multiple pointing reference frames:** Inertial, LVLH, Earth-Fixed, Solar
- **Low jitter** 3-axis reaction wheel control
- **User friendly** software for simulation, integration, and customization

Integrated Spacecraft Design



- XB1 represents a paradigm shift
 - Complete spacecraft bus (GN&C, Power, Thermal, C&DH, RF-Comm, propulsion control, and flight software)
 - Ready straight out of the box, much like laptop computers and smart phones today
 - No programming or assembly required (except for your payload)
- And in the paradigm of smart phones, the XACT-Bus Development and Operations Environment (using model-based design) will provide users the ability to develop their own flight “apps” to operate their payload, process payload data, and control XB1
 - For example, new RPOD algorithms
 - Mission specific onboard processing of payload data
 - The user needs only to provide the mission-dependent payload
- **BENEFITS:**
 - Increased Mission Capabilities (Pointing, Power, RF Comm, Propulsion)
 - Maximizes Payload Volume, Precision and Power Availability

XB1 Maximizes Payload Volume and Capability



Current
Discrete
Components

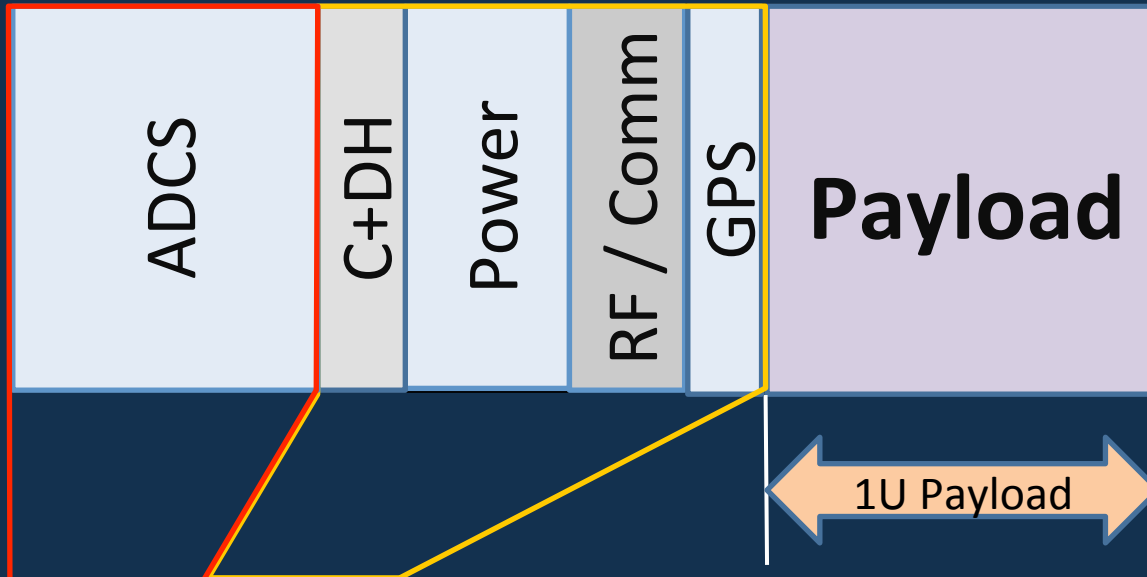

Small payload -->
Limited data/image

XB1
Integrated
System

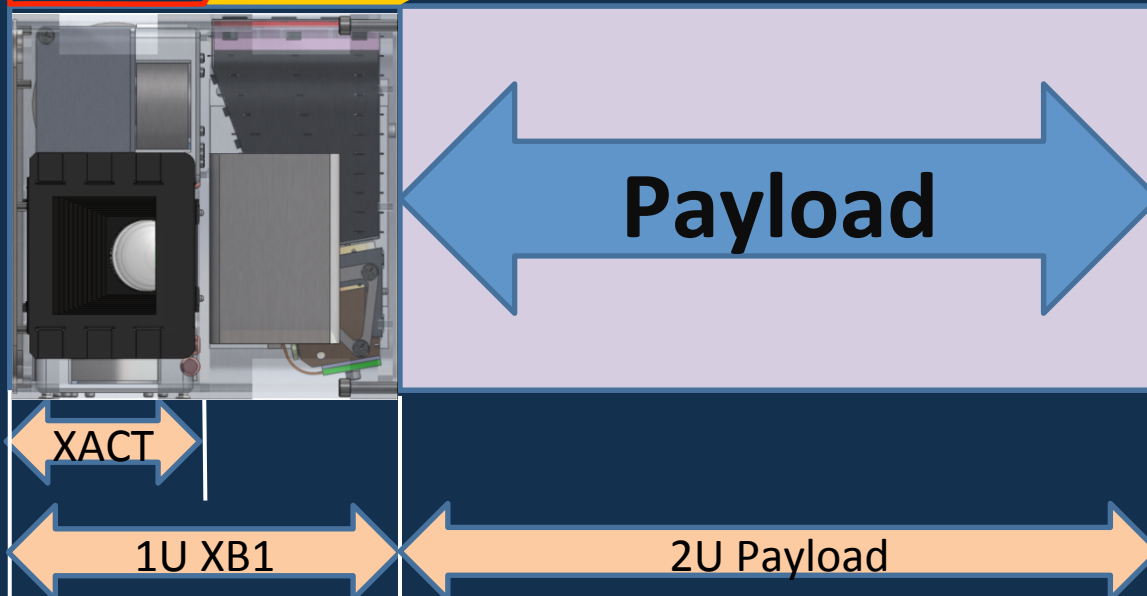

Larger payload -->
Improved data/image

XB1

XACT-Based High Performance CubeSat Bus

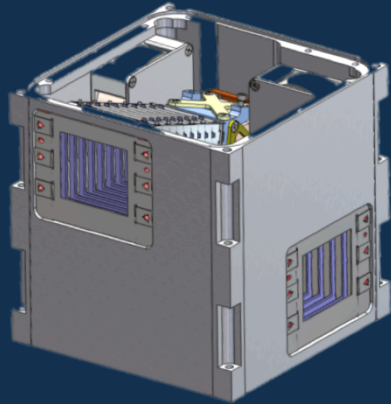

- Highest-available pointing performance from *Dual* Micro-Star Trackers
- Bus functionality for GN&C, EPS, Thermal, C&DH, RF Comm, SSR
- Interfaces and control provided for Payload, Propulsion, and Solar Arrays
- Supports configurations up to 27U
- *Available 2013*

	XB1 Parameter	Value/Notes
GN&C	Pointing Accuracy	$\pm 0.002^\circ$ (1-sigma), 3 axes, 2 Trackers
	Pointing Stability	1 arc-sec/sec
	Maneuver rate	10 deg/sec (typical 3U CubeSat)
	Orbit knowledge	10m, 0.15m/s
CDH	Data Interfaces	Serial: RS-422, I2C, or SPI available
	Onboard Data Processing	Configurable via user loadable "Apps"
	Telemetry Acquisition	16 12bit Analog, 32 discrete inputs
	Commands	Real-time, stored, macro
	Onboard Data Storage	4 Gbytes (option)
EPS	System Bus Voltage	12 ± 2 V
	Energy Storage	>20Whrs
	Payload Power Feeds	QTY 3, 12V or Regulated 1.2V to 5.0V
Comm	Frequency	UHF or SBand
	Uplink	CCSDS, USB, SGLS
	Downlink	250 kbps / 100 Mbps
	Encryption	AES 256
	Solid State Recorder Capacity	4 Gbytes
Prop	Heater Controllers	4 independently controlled zones
	Propulsion System Drive	8 Thruster drivers, 2 Latch Valve Drivers
	Telem. Interfaces	1 Temperature, 1 Pressure, 2 Status
	Mass / Volume	1.5 kg / 10 cm x 10 cm x 10 cm
	XACT-Bus Nominal Power	<2.5W
	Orbit Altitude / Orbit Lifetime	LEO / > 1 year

Integrated Functionality

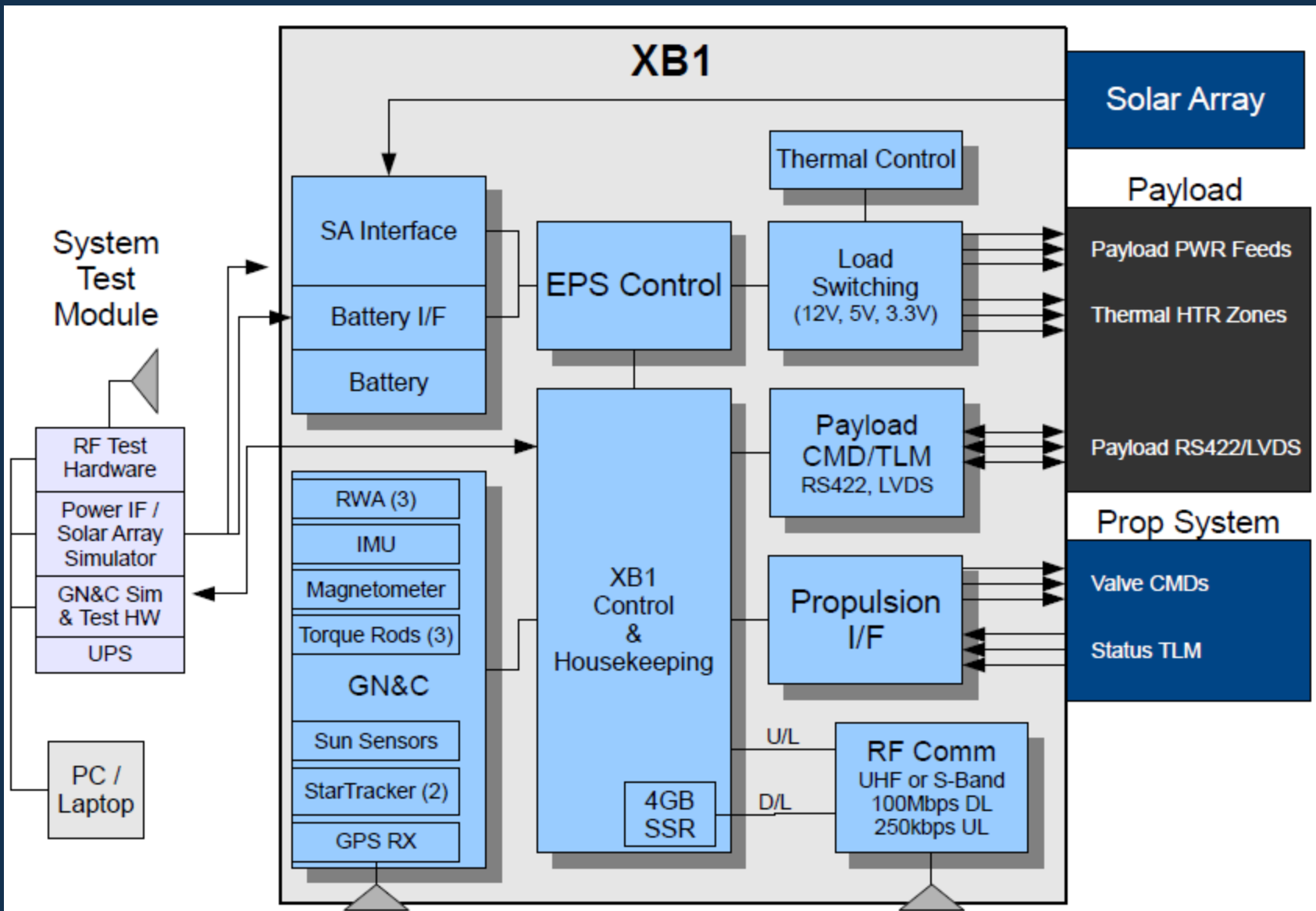

XB1 Flight Software Highlights



- Highly autonomous operation
- Precision stellar-based attitude determination & control
- Supports precision orbit propagation of multiple target objects
- Flexible pointing commands support a wide range of missions
 - *e.g. Inertial, LVLH, Earth-Fixed, Solar, object tracking*
- Supports user-developed payload algorithms (or Apps)
 - *Built-in 'hooks' for high rate, low rate, and asynchronous task processing, with easy access to all XB1 data, including raw star camera images*
 - *XB1 interface functions allow user Apps to receive commands and send telemetry*
 - *XB1 interface functions allow user Apps to command the XB1 (e.g. user RPOD algorithms tell XB1 where to point and how much delta-V to apply)*
- Supports 10,000 stored commands, as well as real-time, macro sequences, and commands from user Apps

XB1 Development & Operations Environment (XDOE)



- XDOE supports user through all stages of satellite life cycle.
- Model-based design (using Matlab/Simulink) supports flight software and simulation software in one unified environment.
- All-software simulation of spacecraft (provided out-of-the-box) supports mission analyses and training.
- Customizable with user payload models and flight 'Apps'.
- Auto-code generation of custom models and Apps.
- Test console supports real-time closed-loop testing of XB1.
- Command, telemetry, and 3d animation displays.
- Generation of uploadable flight parameter tables.

All the tools you need to quickly get to the science

XDOE Simulation Highlights



- Supports constellation of 99 satellites (each independently configured and controlled)
- Variable run speed (<<real-time to >>real-time)
- Command script or GUI control
- Selectable gravity field model with user-friendly initialization command features to support formation flying
- GPS constellation model
- Mag field, aero density, sun, moon, star field models
- High-fidelity GN&C component models
- Built-in 3d animation driver for user-provided VRML model
- Real-time STK “connect” interface, or play-back files supported

XB1 Integrated Command, Telemetry & Animation



Control and visualize the XB1 out of the box

CMD & TLM for XB1 and simulation

User-friendly command GUI

TLM pages support limit checking, yellow & red limits

3D animation for immediate visualization

Z to sat, max sun

Position	X	Y	Z
X	-0.002	0	-0.002
Y	-0.1304	0	-0.1304
Z	0	0.01	-0.01

Velocity [km/s]	X	Y	Z
X	-3.82012	0	0.3861
Y	0	0	0
Z	0	0	-0.0031

Position [km]	X	Y	Z
X	5902.11	3350.25	676.623

Sun Vector	X	Y	Z
X	0.408248	-0.816497	0.408248

Wheel Speed [rpm]	X	Y	Z
X	1098.2	-2003.9	102.4

Torque Rod Cmd	X	Y	Z
X	OnNeg	Off	OnPos

Tank Pressure [psi]	Value
	0.59

Tank Temp [C]	Value
	12.34

Command & Telemetry Demo

The image shows the MATLAB R2012a software interface. The main window is titled 'MATLAB R2012a' and has a menu bar with 'File', 'Edit', 'Debug', 'Parallel', 'Desktop', 'Window', and 'Help'. The current folder is 'C:\Blue Canyon Technologies'. The interface is divided into several panes:

- Current Folder:** Shows a tree view with 'Subsystem GUIs', 'cmd.fig', and 'cmd.m'.
- Command Window:** Contains the MATLAB prompt 'fx >>' and a cursor.
- Workspace:** A table with columns 'Name', 'Value', and 'Memory Usage'. It is currently empty.
- Command History:** Shows a single entry: '--- 8/3/2012 2:34 PM ---'.

The status bar at the bottom left shows 'Start Ready' and the system tray at the bottom right shows 'OVR'.

XB1 Flexible Pointing Demo

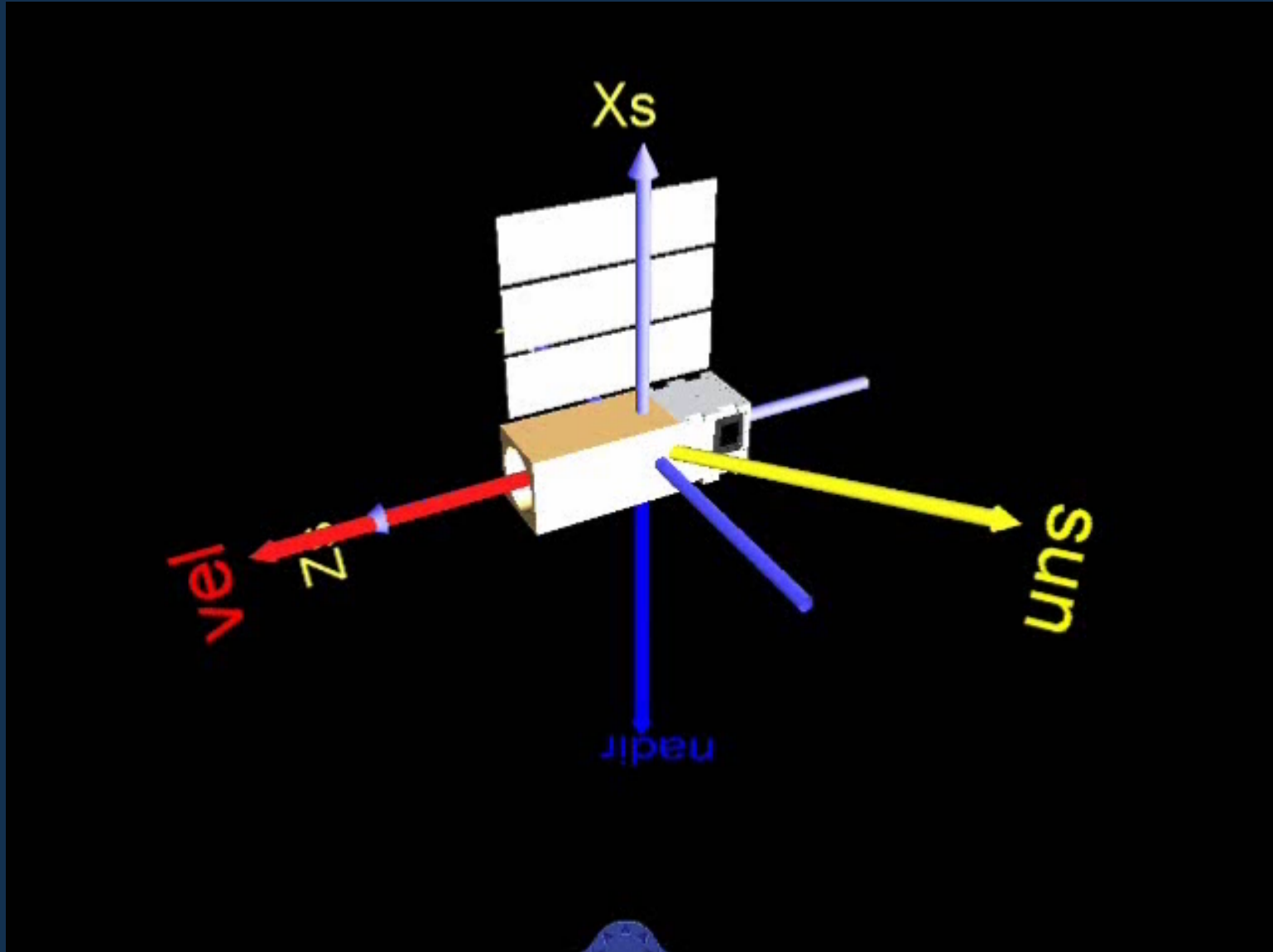

XDOE Formation Flying Configuration (demo 1)



Allows rapid reconfiguration of orbits, even while running



XDOE Formation Flying Configuration (demo 2)



Allows simulation of entire constellations

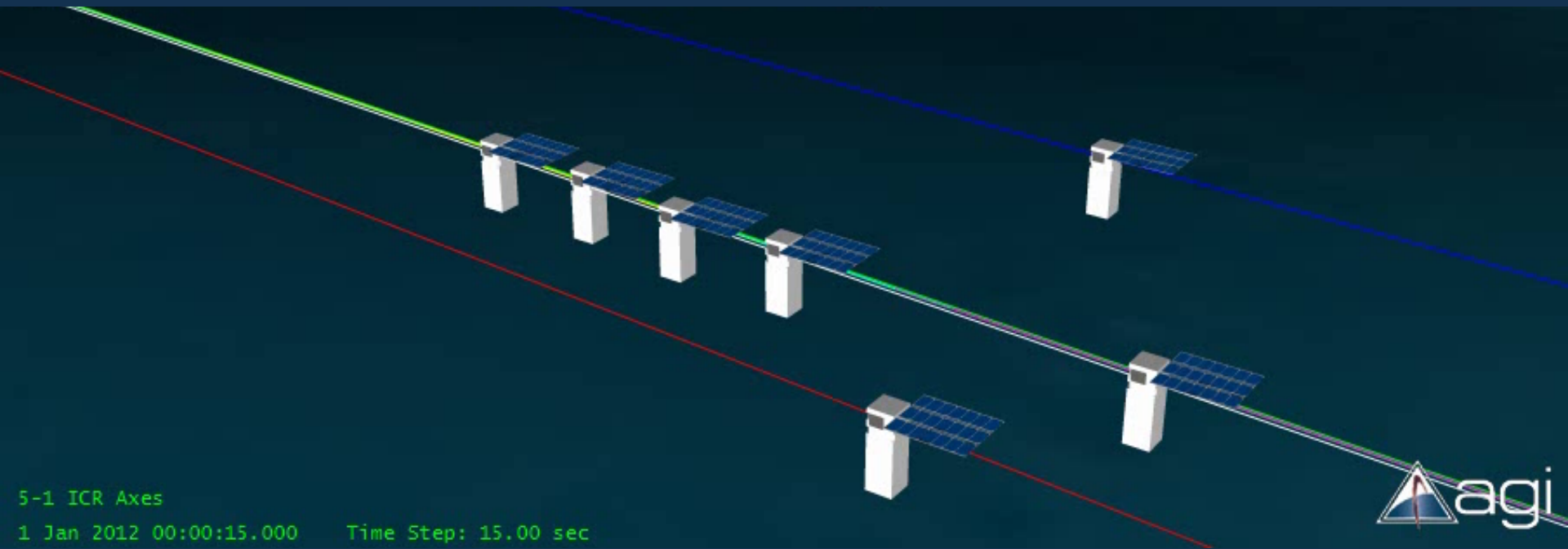

Large Spacecraft Performance in a CubeSat



Precision Pointing

Improved science and mission capabilities

Unified Software & Simulation

Develop, Integrate & Test your own mission code

Compact

*Maximum Payload
Volume*

XB1

Powerful Core

Onboard mission data processing

Easy to Use Interface

Simplifies system development and shortens schedule

Highly Integrated

Simplified system integration

XB1

Enabling A New Realm of CubeSat Science



- Earth Remote Sensing
- Space Situational Awareness
- Rendezvous, Proximity Operations & Docking
- Demonstration of Autonomous Operations
- Formation Flying & Swarms
- Inter-satellite Communications Networks
- Operationally Responsive Space

Teaming With BCT



Contact BCT for more information.

George Stafford

720.458.0703

1600 Range St, Suite 200

Boulder, CO 80301

www.bluecanyontech.com

info@bluecanyontech.com

(While at conference: 303 478-1631)