

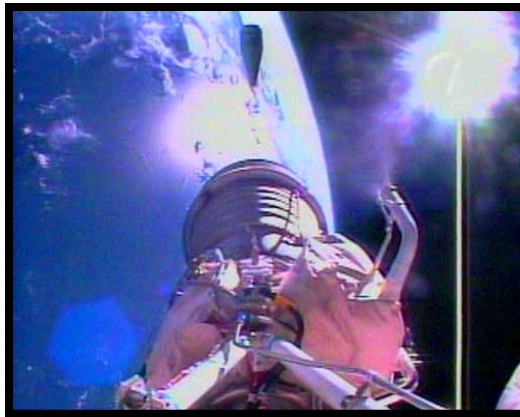

Adapting a RocketCam™ Digital Video Controller Avionics Unit to be a P-POD Deployment/Monitoring Unit

**Riki Munakata and Rex Ridenoure
Ecliptic Enterprises Corporation
Pasadena, CA**



- Based on the externally mounted RocketCam™ system
- 1U CubeSat deployer
 - Can accommodate a slightly larger CubeSat
- Payload is kinematically restrained during launch
- Environmental closeout protects payload after integration
 - Nitrogen purge option available
- Access port available after integration
- Zero-G test (Sep 2004)
- Suborbital test (Aug 2008)

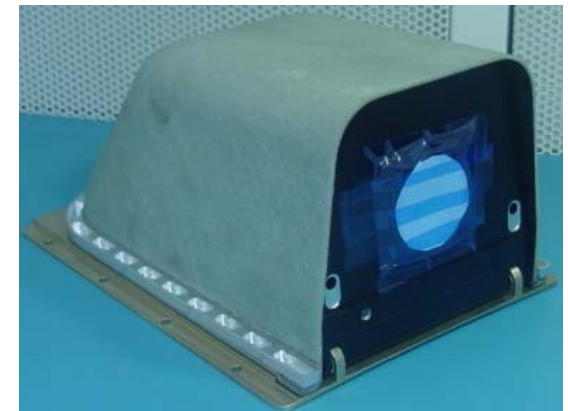
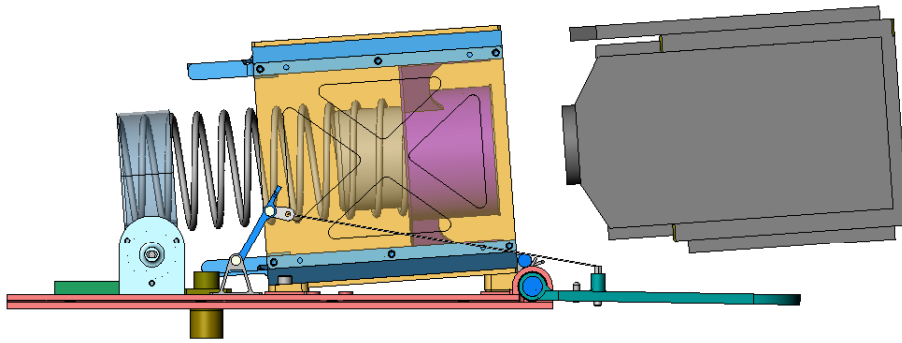
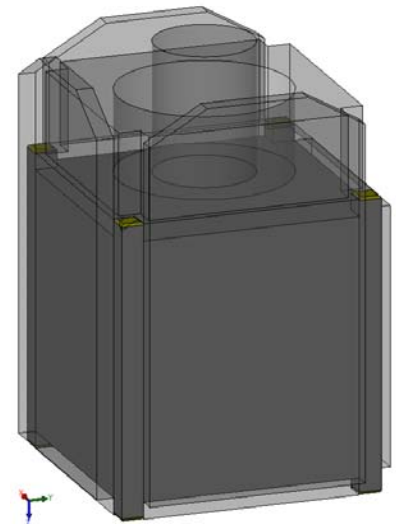



RocketCam™ Digital Video Controller (DVC) cPCI to PC-104 Migration

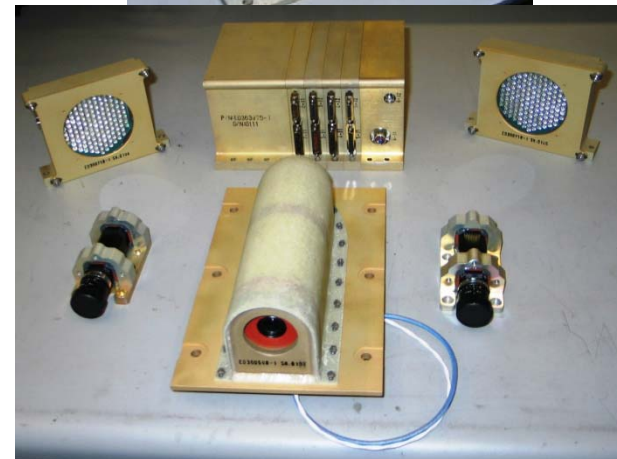
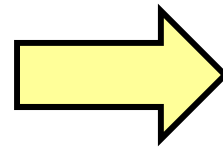
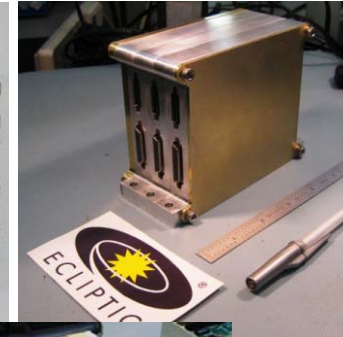
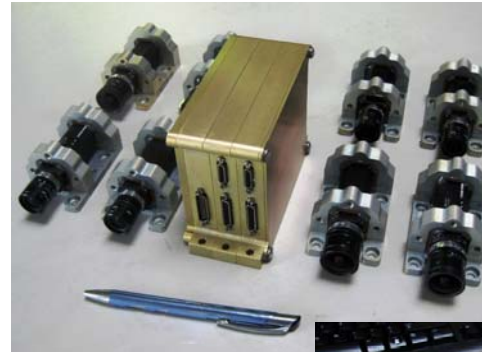



DVC-104 Avionics: Based on PCIe/104 Standard

- Stackable modules support a variety of applications and configurations
 - Launch vehicles, spacecrafts, UAVs, marine systems, combat systems, test facilities, etc.
 - Digital Video System
 - Payload controller / Data handling unit
 - Bus controller
 - Instrument / Data acquisition controller
 - Flight control computer
 - Missile / Launch vehicle managements system

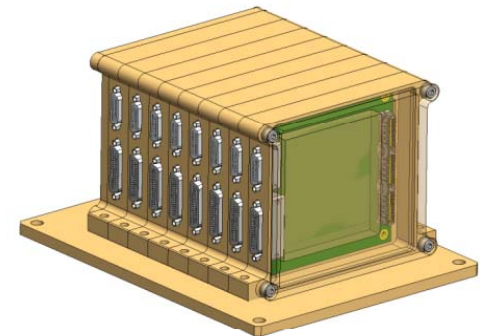

**92 Ecliptic systems launched (85 rockets; 7 spacecraft)
>230 cameras and 19 digital avionics controllers
** No known Ecliptic hardware or software failures ****





Adapting DVC for Deployment Control: Genesis of Concept

- Proposed to DARPA for STTR
 - Phase I and II funded, with Cal Poly SLO as partner
- Employ DVC capabilities to control and monitor multiple P-POD and RocketPod systems
 - Up to 8 deployments
 - Deployment video coverage
 - Environmental data capture

**“RocketPod and
P-POD on
Steroids”**

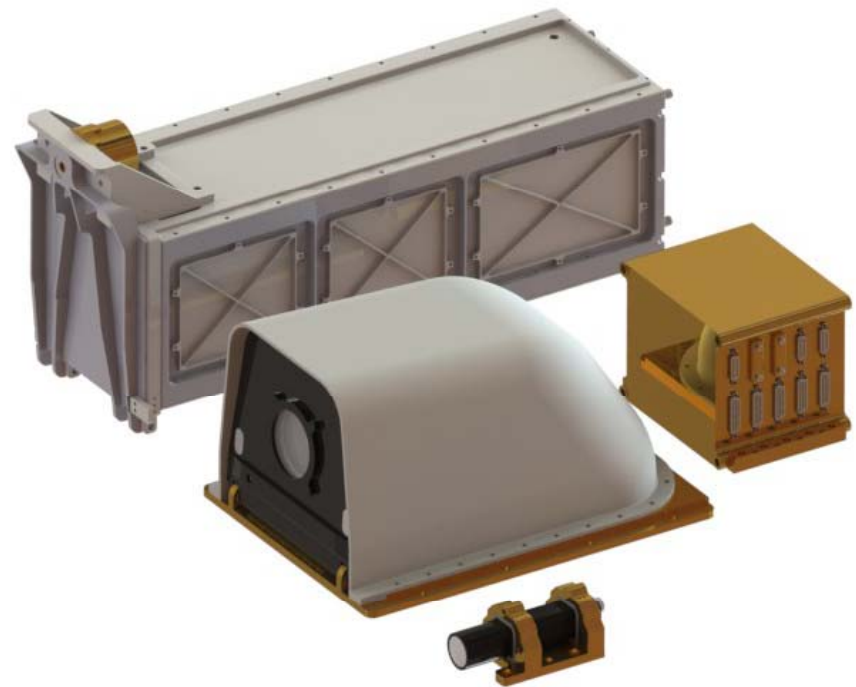

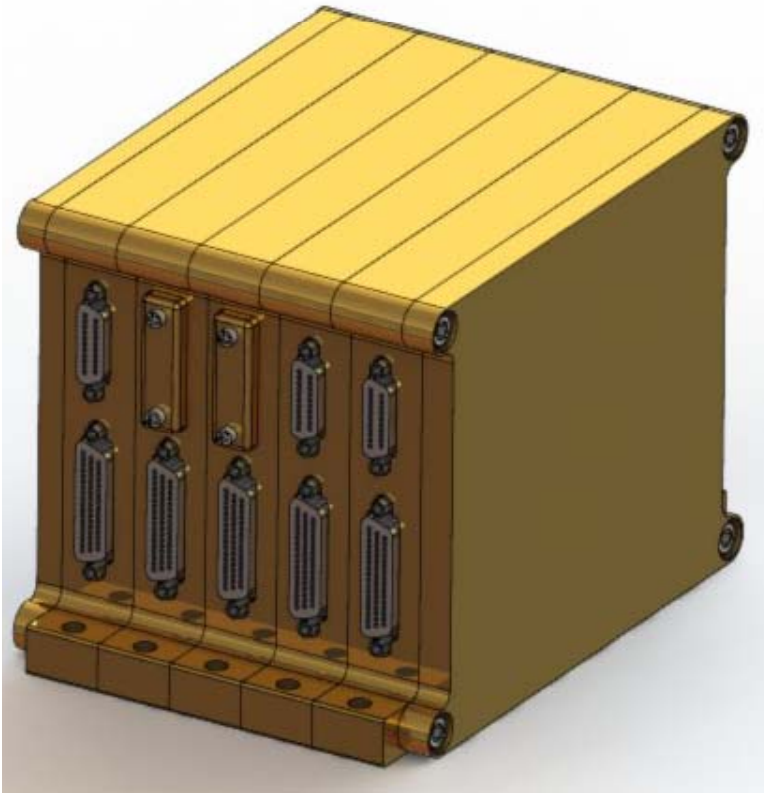

- DVC –104
 - Launch vehicle configuration
 - Size: 99.6mm x 98.5mm x 132.8mm
 - Mass: ~ 1.2 kg
 - 5 slice system
 - 8 NTSC camera inputs
 - 8 actuator drive outputs
 - Supports redundant outputs
 - 8 channel analog inputs (environmental sensors)

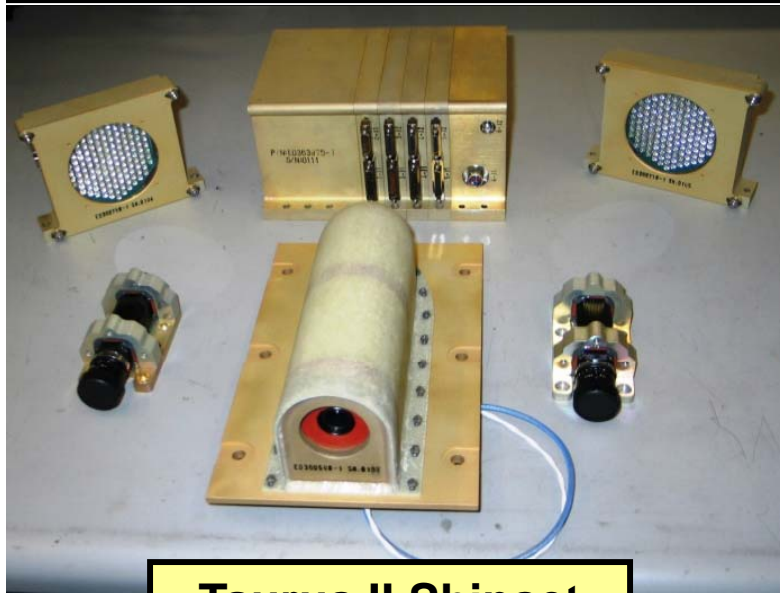

Taurus II Shipset

- Illuminator
 - Independent or camera mount
- High speed and High Definition camera
 - Large selection of sensors from 800x600 @ 500 fps to 4872x3238 @ 3 fps
- Primary/Secondary battery
- S-Band transmitter
 - 150mW to 20W
- Solid State Drive
 - Store and forward applications
 - Up to 320GB





Functional Diagram

Digital Video System (DVS-104)

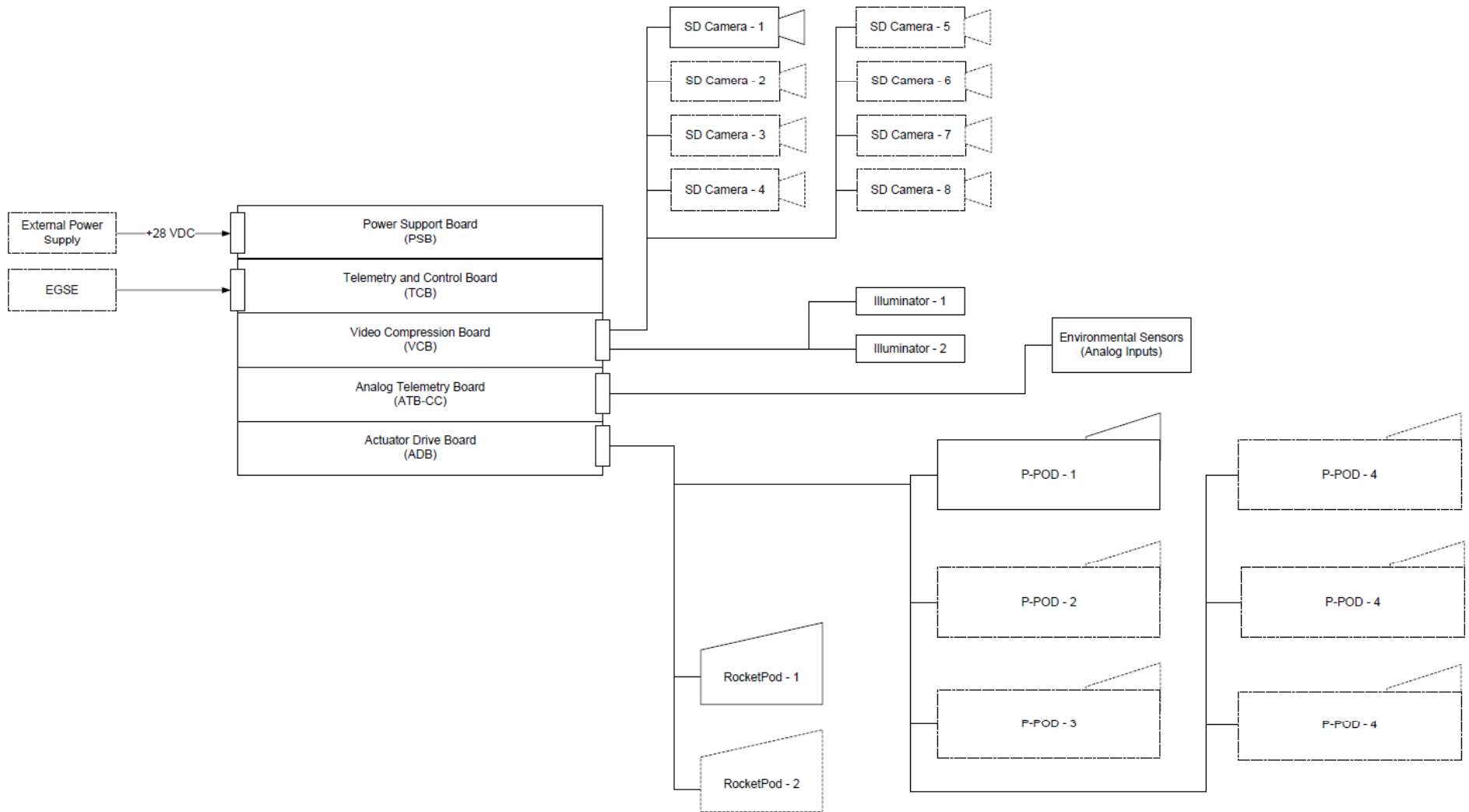

- P-POD + DVC + Care package
- Takes advantage of space on top of P-POD
- Mechanically repackaged DVC-104 form factor
 - Same capabilities as current DVC
 - Does not increase rectangular envelope of P-POD
 - Minimal impact to P-POD design

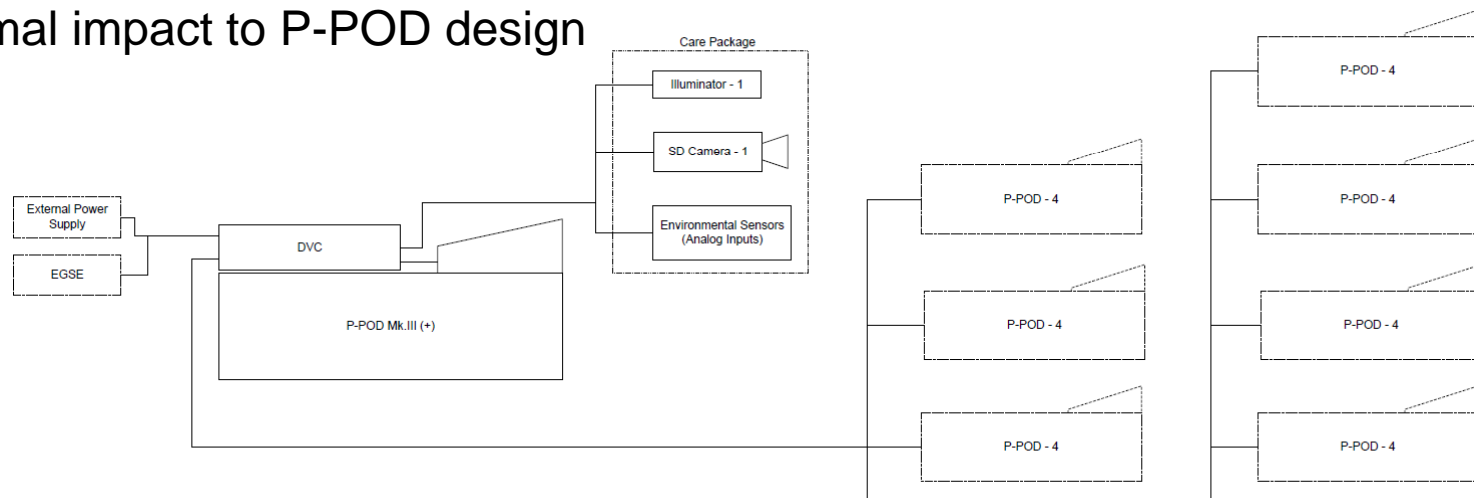
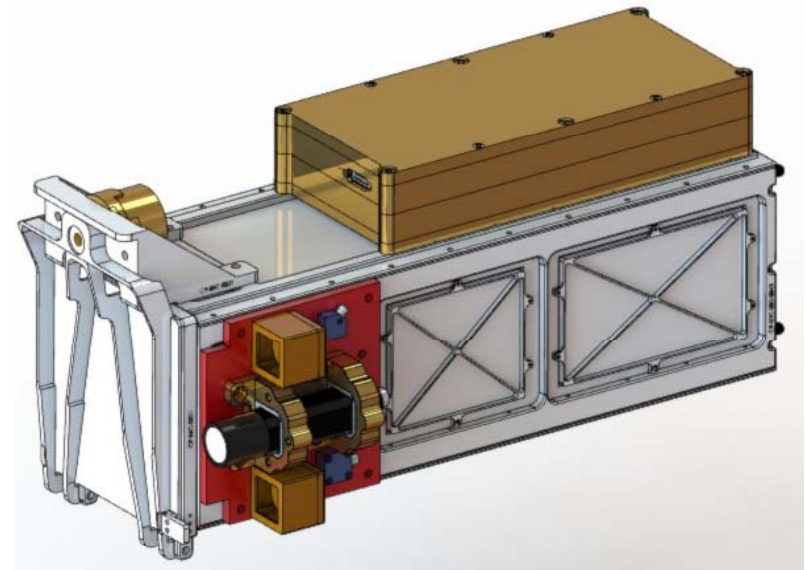

- Phase II STTR completion 2011 2Q
- Sequencer baselined in 2010 for (rescheduled) ADAMSat mission
 - 8 P-PODs on NPS Cul-Lite
- Development on DVC and P-POD Mk.III(+) continued since
- Deliverables expected by end of effort:
 - Launch-ready DVC + 1 cameras (up to 8)
 - Protoflight environmental testing
 - Prototype of P-POD Mk.III(+)
 - Qualification environmental testing
 - Mature EM of RocketPod
- Investigating multiple launch options
 - Environmental testing performed to envelope most launch vehicles





Ecliptic Contact Info

Riki Munakata, Mechanical Engineer
rmunakata@eclipticenterprises.com
(626) 798-2436 x412

Rex Ridenoure, CEO
rridenoure@eclipticenterprises.com
(626) 278-0435

398 W. Washington Blvd., Suite 100
Pasadena, CA 91103
www.eclipticenterprises.com



“RocketCam by Ecliptic”