

CubeStack: CubeSat Space Access

9th Annual
CubeSat Developers' Workshop
Cal Poly San Luis Obispo

19 April 2012

Moog CSA Engineering
2565 Leghorn Street
Mountain View, California

LoadPath
933 San Mateo Blvd NE
Albuquerque, New Mexico

CubeStack Multi-Payload Adapter

- MPA development by LoadPath and Moog CSA
 - Under contract to AFRL Space Vehicles Directorate
- Adapter similar in function to ESPA
 - CubeSats mounted in 10-inch adapter between payload interface and primary payload
 - Accommodates eight 3U CubeSat dispensers
 - or four 6U CubeSat dispensers
 - or other combinations of 3U and 6U dispensers

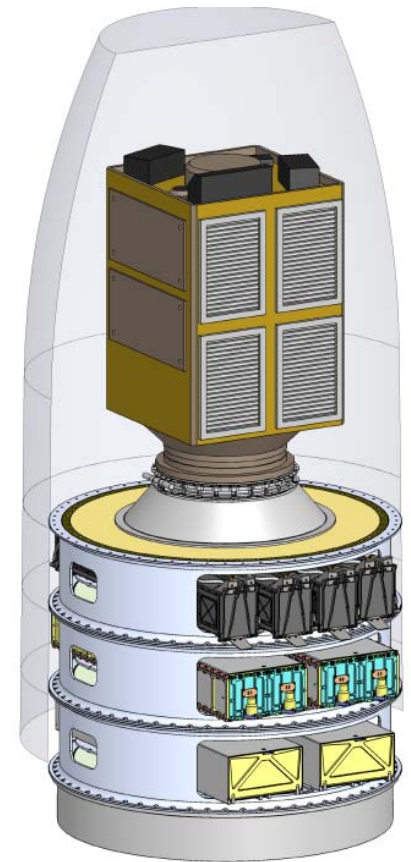

CubeStack Primary Payloads

- Sized for Athena, Minotaur, Taurus, Pegasus, Falcon 1
- Primary interfaces
 - Ø38.81-inch (Ø98.6-cm)
 - Ø24.00-inch (Ø61.0-cm)
- Primary payload capability
 - 1000 lb (454 kg) on Ø38.81-inch interface
 - 500 lb (227 kg) on Ø24.00-inch interface

	Maximum Payload Mass	Axial Load Factor*	Lateral Load Factor*	Payload CG	Separation System Offset	Adapter Offset	Total CG Offset**
Primary Payload Interface	kg (lbm)	g's	g's	cm (in)	cm (in)	cm (in)	cm (in)
Ø98.6 cm (Ø38.81 inch)	454 (1000)	±6.6	4.2	82.80 (32.60)	5.42 (2.13)	0.00	88.22 (34.73)
Ø61.0 cm (Ø24.00 inch)	227 (500)	±6.6	6.3	55.88 (22.00)	5.42 (2.13)	13.86 (5.46)	75.15 (29.59)

*Quasi-static load factor

**Total maximum distance from primary payload interface to payload CG.

CubeStack Secondary Payloads

- CubeSat dispensers mount to CubeStack interior on customizable mounting plates
 - P-POD
 - Planetary Systems 6U canister
 - NASA Ames NanoSat Launch Adapter System (NLAS) dispenser
- Dispensers protrude through opening to facilitate door opening and payload deployment
 - Plates can be modified for attachment of other dispenser systems
- Designed for dispenser plus CubeSat total mass of 23.1 lb (10.5 kg) per 3U
 - Total of 185 lb (83.9 kg)

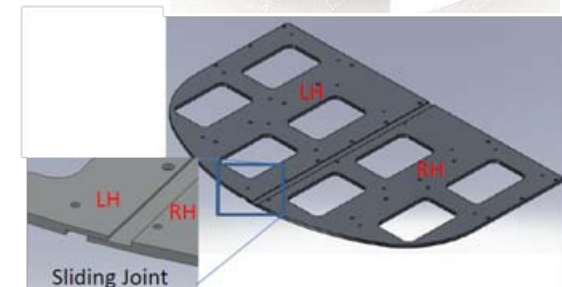
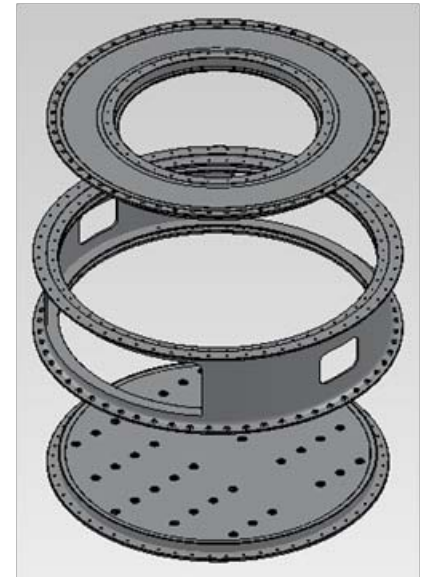

CubeStack Structure Design

- Primary cylindrical structure machined from 7075-T6 aluminum ring forging
- Removable sandwich panel decks
 - 7075-T6 aluminum alloy facesheets
 - 5056 aluminum alloy honeycomb core
- Total structure mass 104.1 lb (47.3 kg)
 - Mass without dispensers or CubeSats
 - Upper deck (~25 lb) can be removed for multiple CubeStack mission
- Interior access
 - Two 24.0" x 7.0" (61.0 cm x 17.8 cm) main payload openings
 - Two 6.0" x 4.0" (15.2 cm) access doors
 - ~Ø23" (~Ø58 cm) opening on upper deck
- Dispensers bolted to 6061-T6 aluminum mounting plates attached to aft deck
 - Potted inserts provide mounting plate attachment locations

CubeStack Analysis

- Finite element analysis to optimize/validate design and support static qualification and vibration tests
- Design optimization
 - Minimize weight with positive strength margins while monitoring manufacturing and assembly processes
 - Down-select process: candidate designs evaluated for strength, stiffness, load peaking, buckling, weight
- Static test configurations analyzed using loads environments from candidate launch vehicles
 - Predictions for qualification test strains and displacements
- Random vibration test analysis
 - Select load levels
 - Predict vibration mode shapes of test stack
 - Compute acceleration transmissibility functions for mode identification

CubeStack Static Qualification Test

- Dedicated qualification test verified that flight-representative structure meets requirements of strength and stiffness when subjected to 1.25 times limit load
 - Qualification test also used to correlate model
- Success criteria achieved: CubeStack is qualified for flight

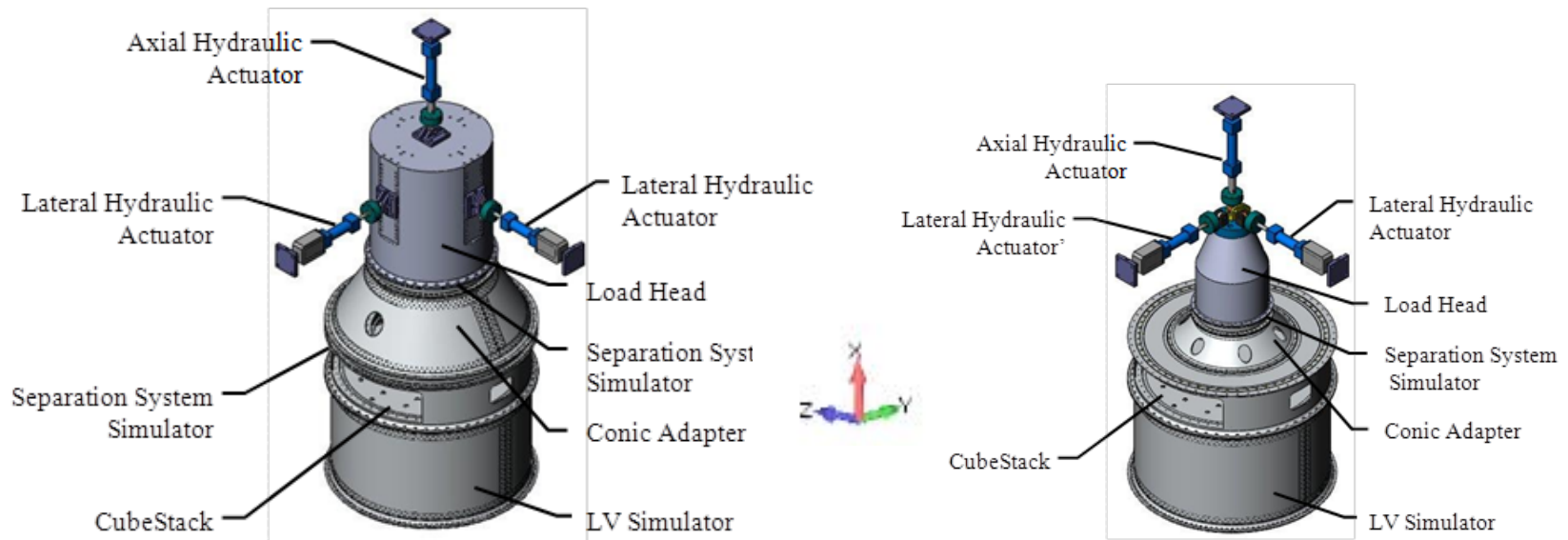

Static Test Hardware

- Loads applied using multi-channel load control system with integrated data acquisition
 - Acquire load, strain, and displacement data
 - Independently controlled hydraulic actuators apply loads as required for each test configuration and simulated environment
- One of two test configurations shown



AFRL Space Vehicles Directorate
Static Test Facility

Static Testing Summary

14 Load Cases

- 4 stiffness cases assessed axial stiffness with low-level loads
- 4 qualification cases for 500-lb primary interface
- 4 qualification cases for 1000-lb primary interface
- 2 aft deck cases for CubeSat dispenser interfaces

Load Case	Description	Flight Loads (100%)			Qualification Loads (125%)			Lateral Offset**
		Axial Load kN (lbf)	+Y Lateral Load* kN (lbf)	+Z Lateral Load* kN (lbf)	Axial Load kN (lbf)	+Y Lateral Load* kN (lbf)	+Z Lateral Load* kN (lbf)	
1	∅98.6cm Stiffness - Comp.	-42.2 (-9485)	0	0	N/A	N/A	N/A	N/A
2	∅98.6cm Stiffness - Tension	42.2 (9485)	0	0	N/A	N/A	N/A	N/A
3	∅61.0cm Stiffness - Comp.	-41.8 (-9400)	0	0	N/A	N/A	N/A	N/A
4	∅61.0cm Stiffness - Tension	41.8 (9400)	0	0	N/A	N/A	N/A	N/A
5	∅98.6cm Qual 1-Comp.	-29.4 (-6600)	18.7 (4200)	0	-36.7 (-8250)	23.4 (5250)	0	88.22 (34.73)
6	∅98.6cm Qual 1-Tension	29.4 (6600)	18.7 (4200)	0	36.7 (8250)	23.4 (5250)	0	88.22 (34.73)
7	∅98.6cm Qual 2-Comp.	-29.4 (-6600)	14.3 (3217)	12.0 (2700)	-36.7 (-8250)	17.9 (4022)	15.0 (3375)	88.22 (34.73)
8	∅98.6cm Qual 2-Tension	29.4 (6600)	14.3 (3217)	12.0 (2700)	36.7 (8250)	17.9 (4022)	15.0 (3375)	88.22 (34.73)
9	∅61.0cm Qual 1-Comp.	-14.7 (-3300)	14.0 (3150)	0	-18.3 (-4125)	17.5 (3938)	0	75.15 (29.59)
10	∅61.0cm Qual 1-Tension	14.7 (3300)	14.0 (3150)	0	18.3 (4125)	17.5 (3938)	0	75.15 (29.59)
11	∅61.0cm Qual 2-Comp.	-14.7 (-3300)	10.7 (2413)	9.0 (2025)	-18.3 (-4125)	13.4 (3016)	11.3 (2531)	75.15 (29.59)
12	∅61.0cm Qual 2-Tension	14.7 (3300)	10.7 (2413)	9.0 (2025)	18.3 (4125)	13.4 (3016)	11.3 (2531)	75.15 (29.59)
13	Aft Deck - Qual Comp.	-24.7 (-5556)	0	0	-30.9 (-6945)	0	0	N/A
14	Aft Deck - Qual Tension	24.7 (5556)	0	0	30.9 (6945)	0	0	N/A

* Applied at payload CG, i.e. 'Lateral Offset'

** Distance from the CubeStack primary payload interface

Strength Margin Predictions

Load Case	Component	Material Heat Treat	Material Properties		Stress Results	Factors of Safety		Margins of Safety	
			Yield Strength (ksi)	Ultimate Strength (ksi)	Max Von Mises Stress (ksi)	F.S. Yield	F.S. Ultimate	M.S. Yield	M.S. Ultimate
1	Wafer	Al 7075-T6 AMS-QQ-A-367	58.0	69.0	3.4	1.25	1.4	12.6	13.4
2					3.4			12.6	13.4
5					16.5			1.8	2.0
6					16.5			1.8	2.0
7					17.8			1.6	1.8
8					17.8			1.6	1.8

Pre-test strength analyses of both test configurations showed high positive margins on ultimate material yield strengths

Note: Load Cases 1-4 are "stiffness" cases, not qualification cases

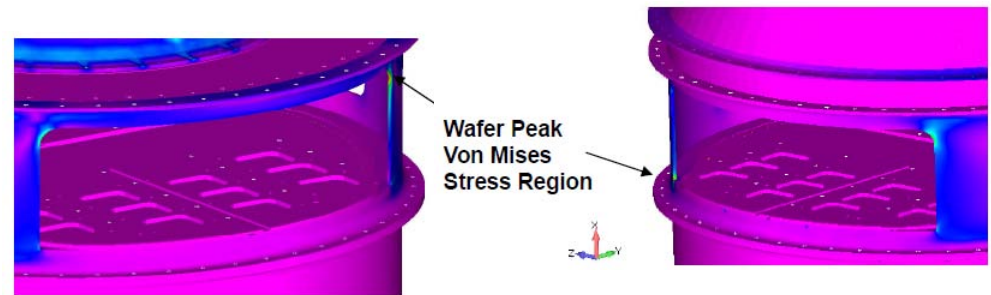

Load Case	Component	Material Heat Treat	Material Properties		Stress Results	Factors of Safety		Margins of Safety	
			Yield Strength (ksi)	Ultimate Strength (ksi)	Max Von Mises Stress (ksi)	F.S. Yield	F.S. Ultimate	M.S. Yield	M.S. Ultimate
3	Wafer	Al 7075-T6 AMS-QQ-A-367	58.0	69.0	13.3	1.25	1.4	2.48	2.70
4					13.3			2.48	2.70
9					22.5			1.06	1.19
10					22.5			1.06	1.19
11					22.5			1.06	1.19
12					22.5			1.06	1.19

CubeStack Dynamic Testing

- Test series to expose assembly to dynamic loads
- Primary objective: model validation and verification of inputs
 - Test sequence is not a qualification test
- Secondary objectives
 - Develop database for estimating modal damping ratios
 - Estimate natural frequencies of low-order modes
 - Determine structural dynamics sensitivity to load level
 - Demonstrate workmanship of assembly under flight-traceable dynamic loading conditions
 - Acquire measurements to derive CubeSat dispenser vibration environments

Dynamic Test Sequence

Dynamic inputs in thrust and two lateral directions

- Swept sine
 - Low level inputs to estimate damping and natural frequencies
- Broadband random
 - Identify nonlinear structural behavior
- Shaped random
 - Minotaur I maximum predicted environment (MPE) used to expose test stack to flight-traceable conditions

Accelerometer measurements used for modal parameter estimation and comparisons with model predictions

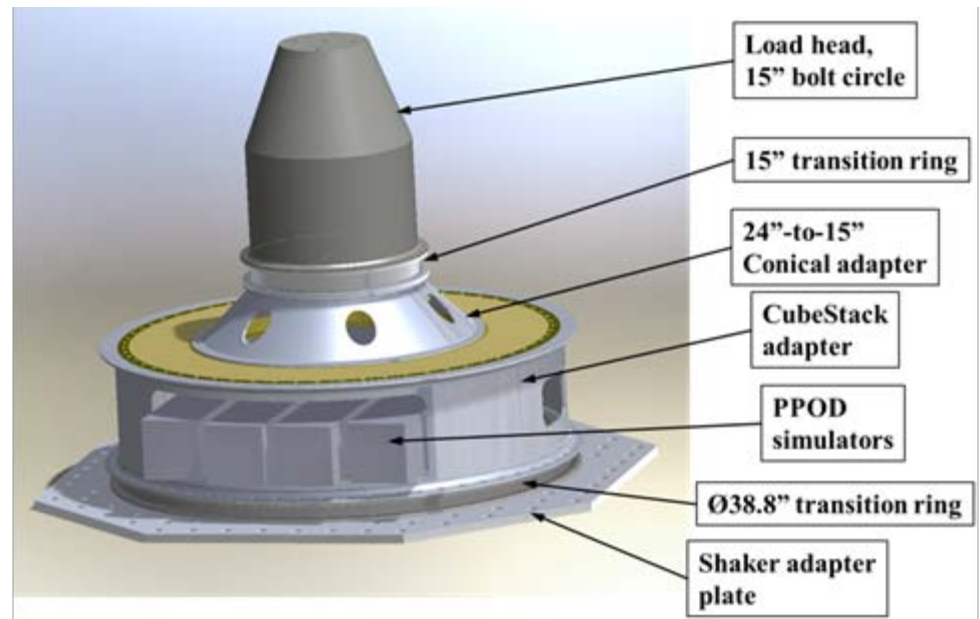

Flight Adapters and Future Development

- Two flight structures currently in production
 - Additional units available as needed starting 3rd quarter 2012
- Second generation CubeStack design
 - Bulkhead configuration eliminates lower deck
 - Weight reduced by 15%-20%
 - Improved access for integration
- CubeStack propulsion module
 - Configurations based on hydrazine or ADN-based HPGP

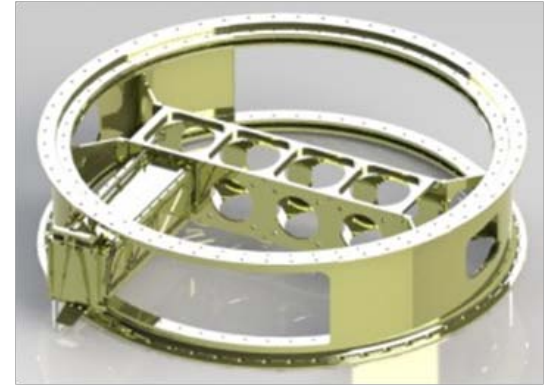

Acknowledgement of Support and Disclaimer

This material is based upon work supported by the United States Air Force under Contract No. FA9453-11-C-0192. Any opinions, findings and conclusions or recommendations expressed in this material are those of the author(s) and do not necessarily reflect the views of the United States Air Force.