

# OUFTI - 1

The CubeSat developed at  
the University of Liège,  
BELGIUM 

Renaud Henrard, Dept. of Electrical Engineering, ISIL

Gauthier Pierlot, Dept. of Aerospace & Mechanical Engineering, ULg

Damien Teney, Dept. of Electrical Engineering & Computer Science, ULg

V. Beukelaers, L. Chiarello, N. Evrard, S. Hannay, J. Hardy,  
L. Jacques, P. Ledent, F. Mahy, P. Thirion, J. Wertz

# Liège, Belgium

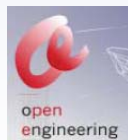

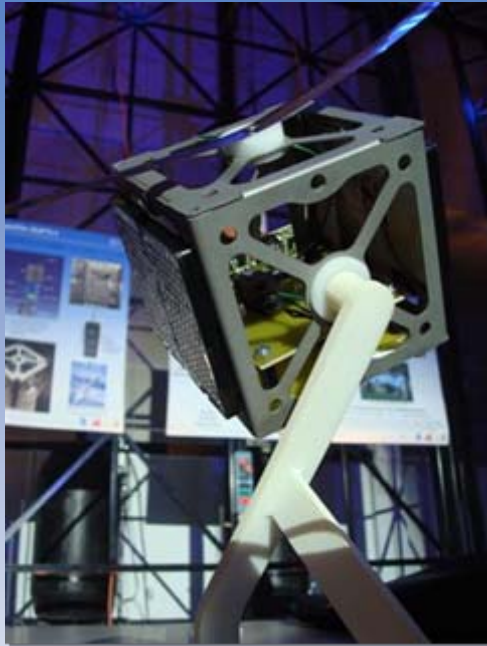

Primary objective:  
hands-on satellite  
experience  
**for students**



## Three payloads

- new radio communication system
- new high performance solar cells
- innovative electrical power system



# Exploded view of our CubeSat

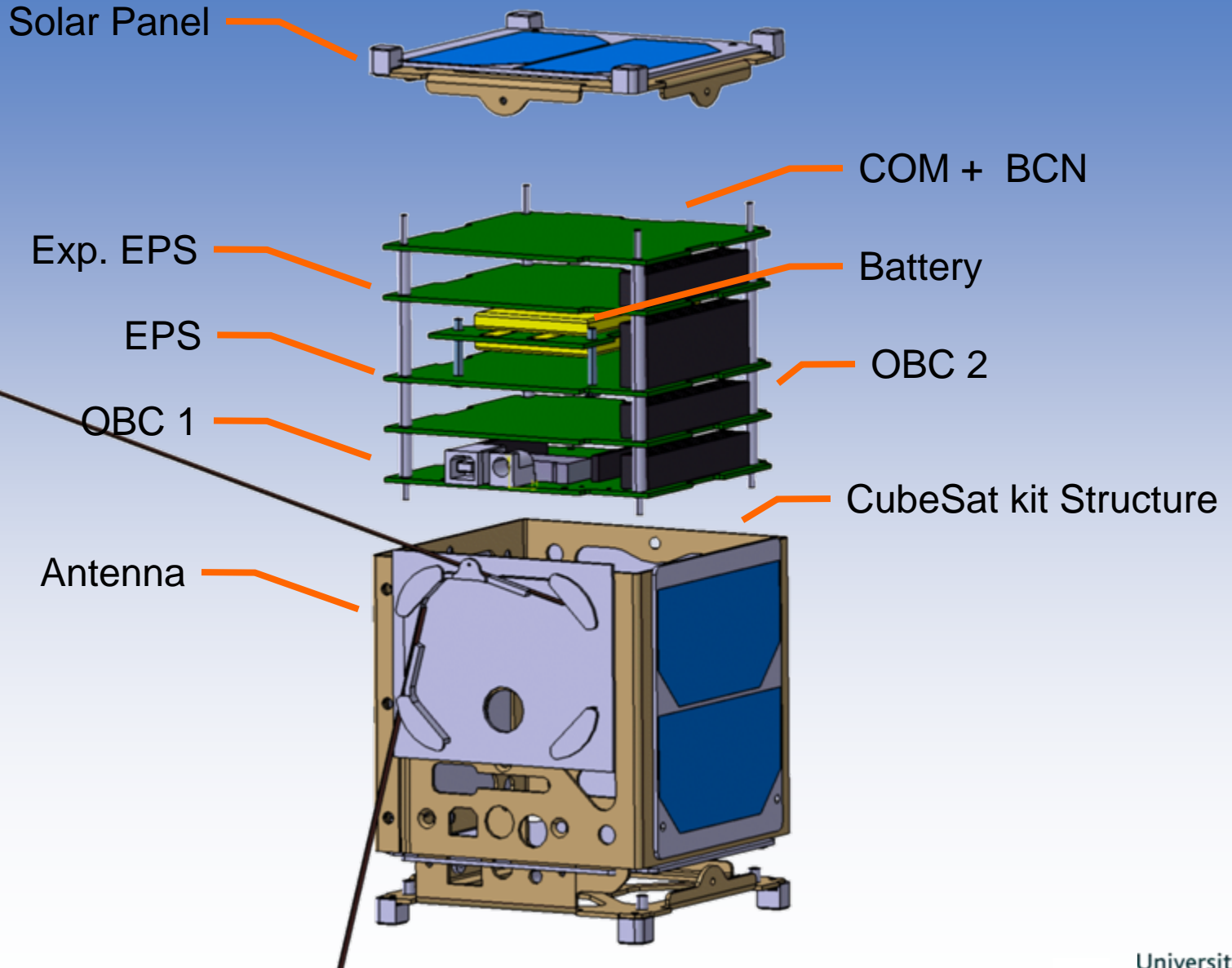

## Digital Smart Technologies for Amateur Radio

- Digital protocol for ham-radio communications
- Simultaneous data and voice transmission
- 2 transmission modes:
  - Data Voice : 4800bps = 3600bps (voice) + 1200bps (data)
  - Digital Data : 128Kbps (data only)
- Modulation : GMSK / QPSK
- Frequency bands : VHF/UHF/SHF



- Direct communication
- Local communication through repeater

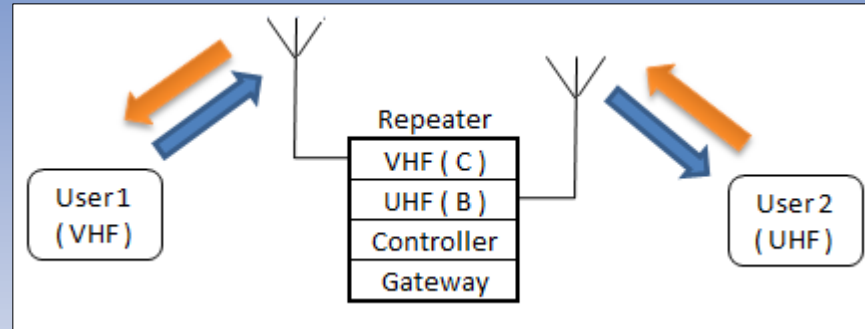

- Communication through gateway

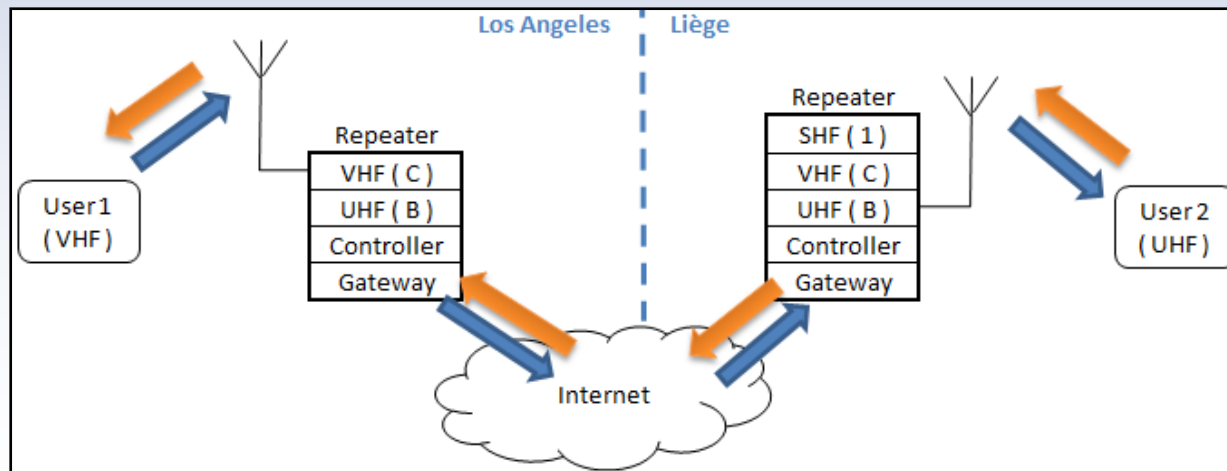

## OUFTI-1 = D-STAR Repeater in space

- UHF uplink / VHF downlink
- DV mode only (GMSK / 4800bps)
- Dual adaptive on-board Doppler compensation
- Up to 10 minutes of continuous D-STAR communication time
- Slots for custom compensation to be requested on our website

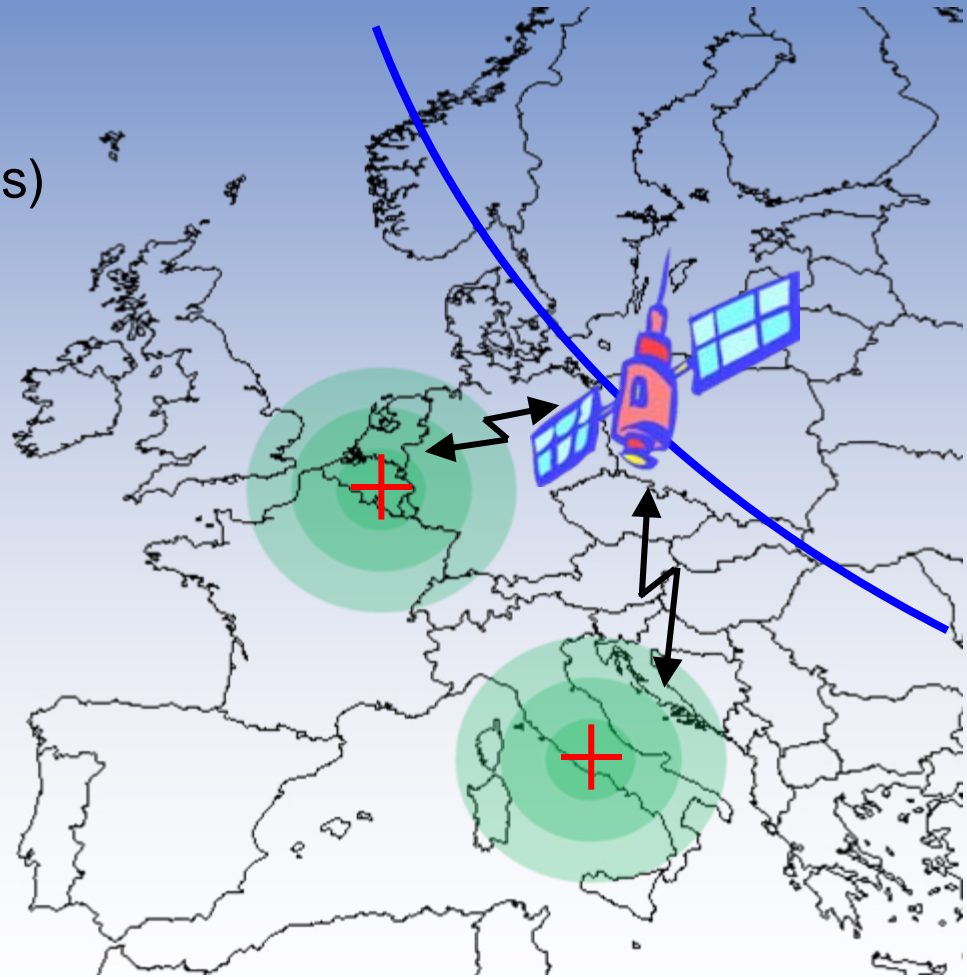

Our D-STAR system: based on

# ADF 7021

integrated transceivers

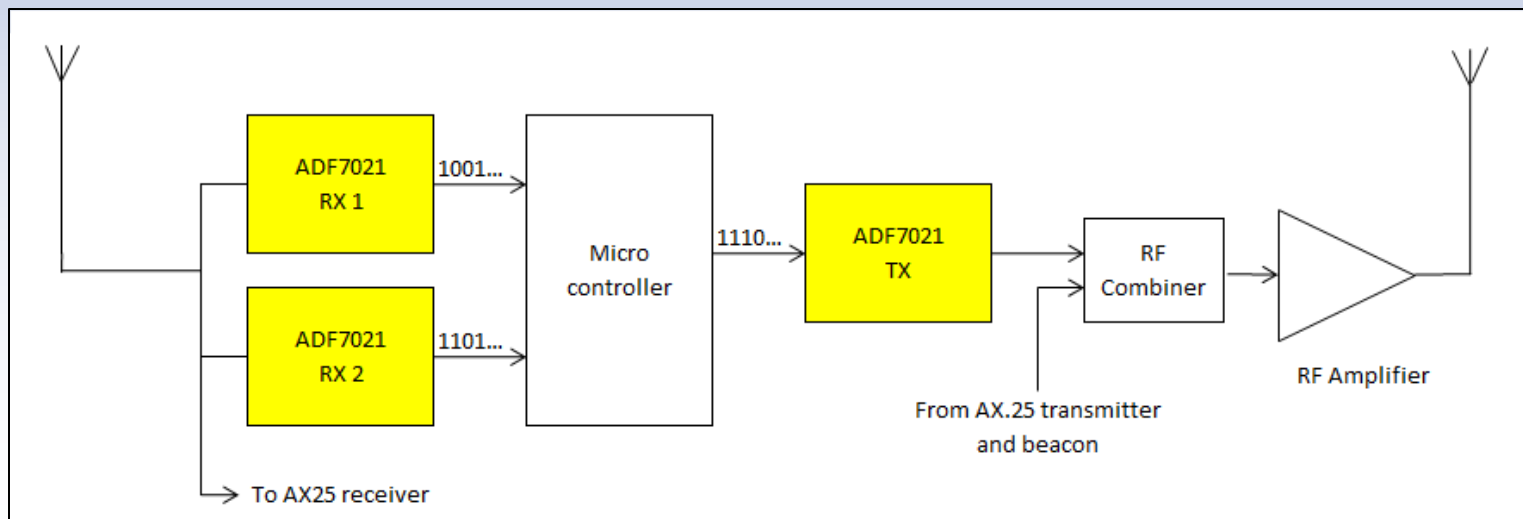

- **Experimental electrical power supply**

Switching power supply with experimental digital control

In collaboration with



- **New solar cells**

High efficiency (30%)

5 complete panels

Measurements will be done in orbit

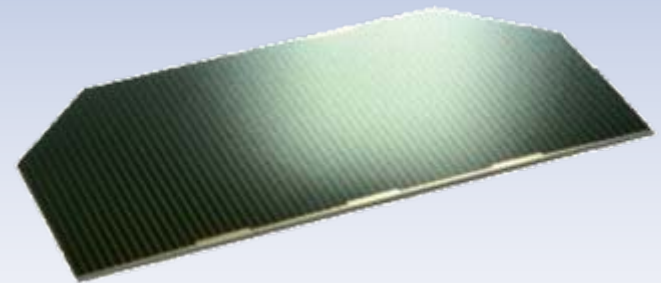

In collaboration with



- **Baseline** simplicity for reliability
- **Off-the-shelf solution**  
Pumpkin's FM430  
Sufficient for all the tasks
- **Drawback: lack of redundancy**  
→ Second processor on a second custom board  
Only one processor active at a time

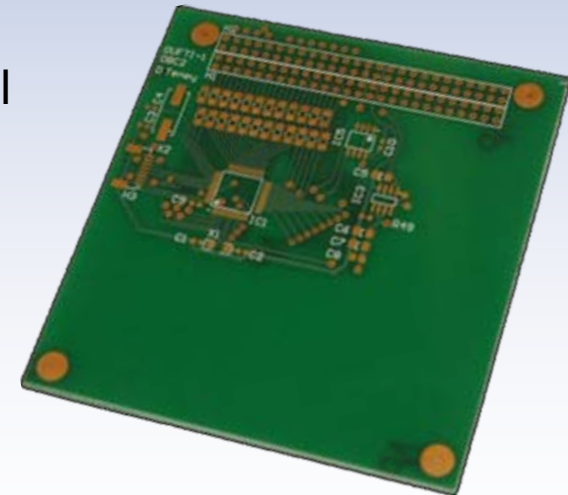
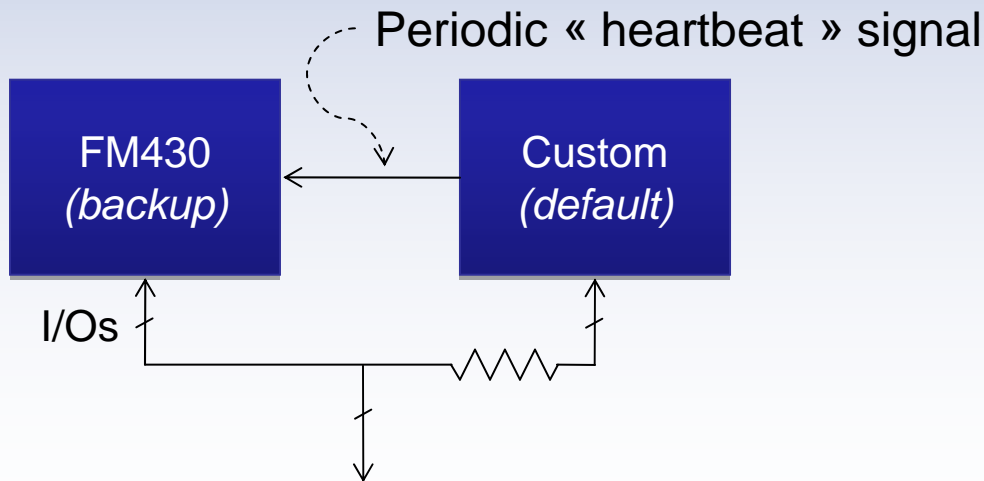
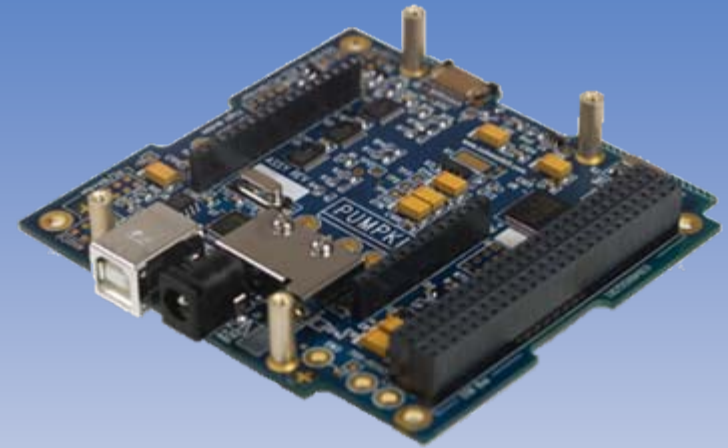

- Great hands-on experience for students
- Innovative technical solutions
- Enthusiastic response from everyone (not only in the university !)
- Raise interest in aerospace engineering



THANK YOU !



<http://www.oufti.ulg.ac.be>

[jpisane@ulg.ac.be](mailto:jpisane@ulg.ac.be)