



Electra

As a tether mission from a PPOD

Electra



Outline

- Electra Mission
- P.P.O.D. Adaptations
- Low Inclination Operations

Description

- Deploy ~1km electrodynamic Hoytether® between cubesat and rocket
- Measure position of endmass
- Originally designed for RocketPod©

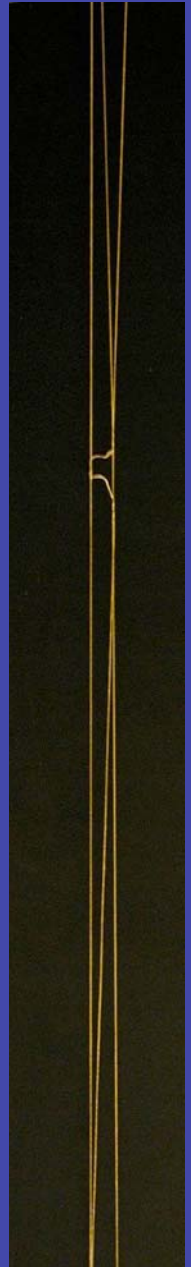
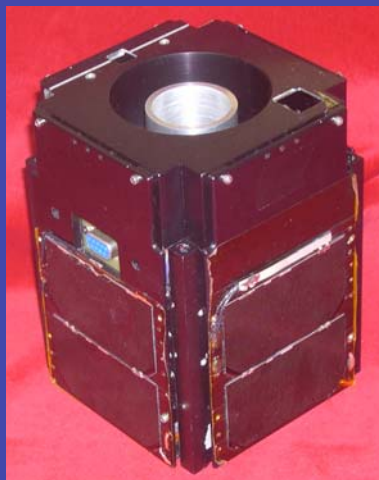

Motivation

- Tether Physics
 - Classical Dynamics
 - Electromagnetic Interaction
 - Survivability
- Practical Deorbit Test
 - Pudding test

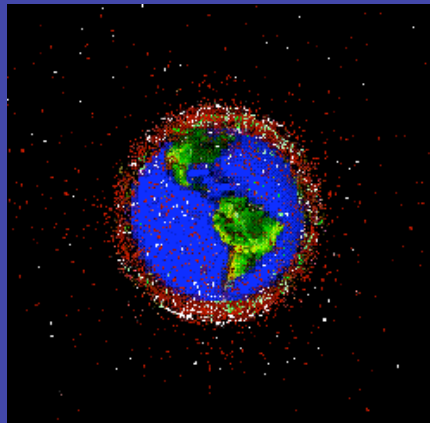

RocketPod® history

- Structure had successful integration
- 2.0 structure version (fabrication timeframe ~months)
 - Designed to cover PPOD and RocketPod specs
- Tie-on requirement met

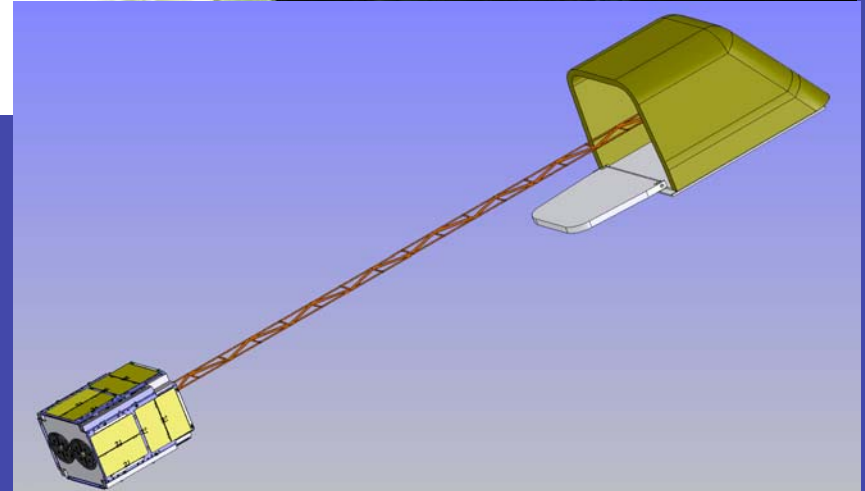
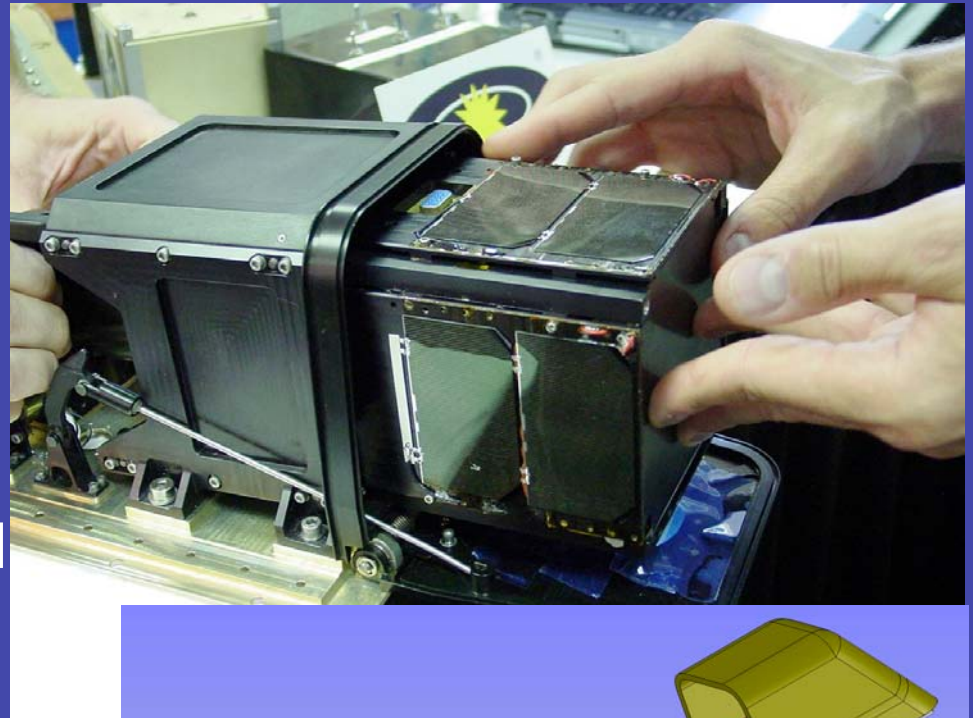

PPOD deployment

- Mission Requirements unchanged
 - Tie-on (integration)
 - Pointing
- New Issues (structural modifications)
 - Double cube form factor
 - Deployment buddy interference
 - Isolation engineering (supply mount point for tether)

Tether attachment

Anchor Cube + Deployer cube

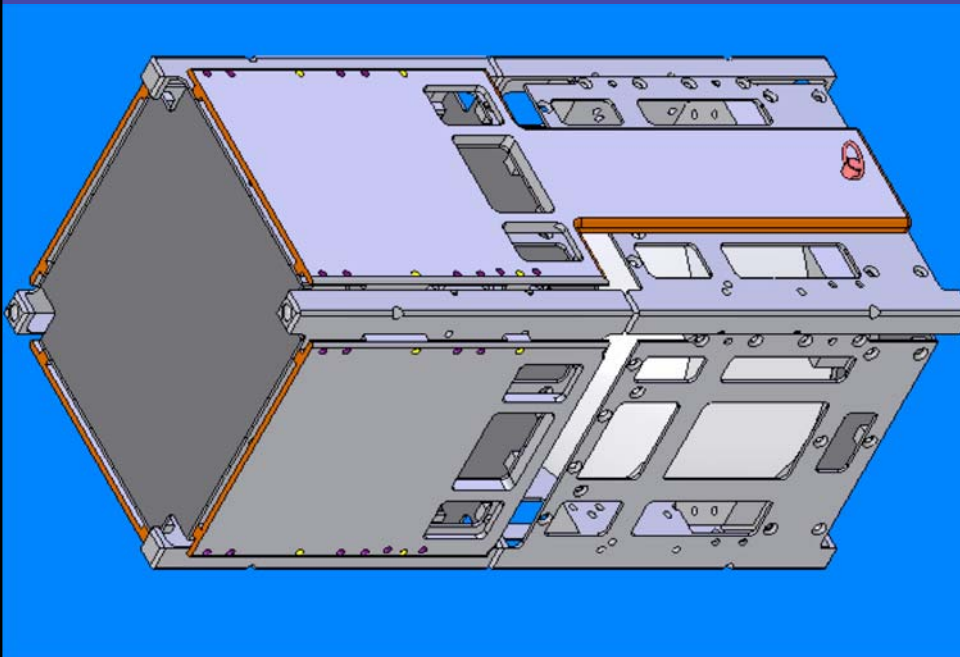

Self contained

Double Deployer

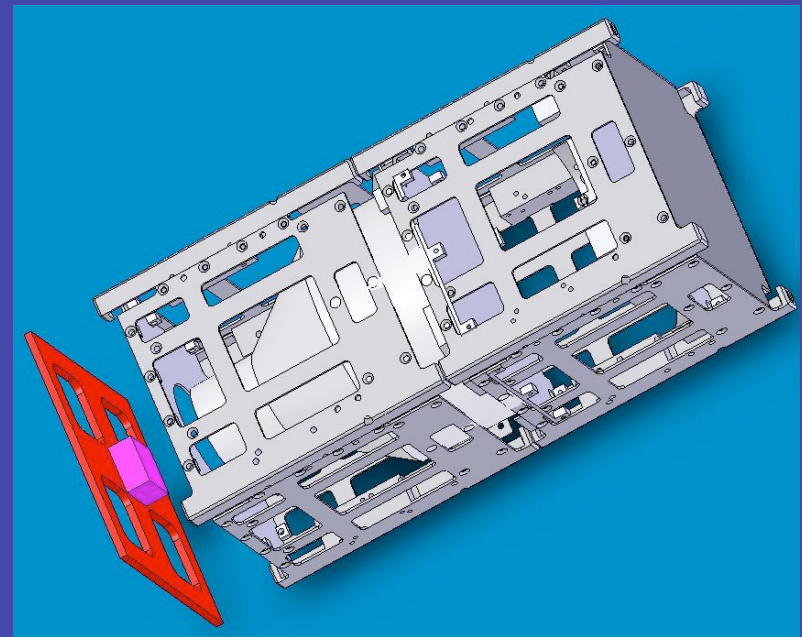

KISS

Possible Isolation solutions

- No Tie-On
 - Bolted to Plunger Plate
 - Creating Interference With a Modified P-Pod Access Port Cover
 - Creating a mechanical Interference With P-Pod muzzle Fillets
- Tie-on

Bolted to Plunger Plate

Plunger Plate is bolted to the CubeSat using the feet of the CubeSat.

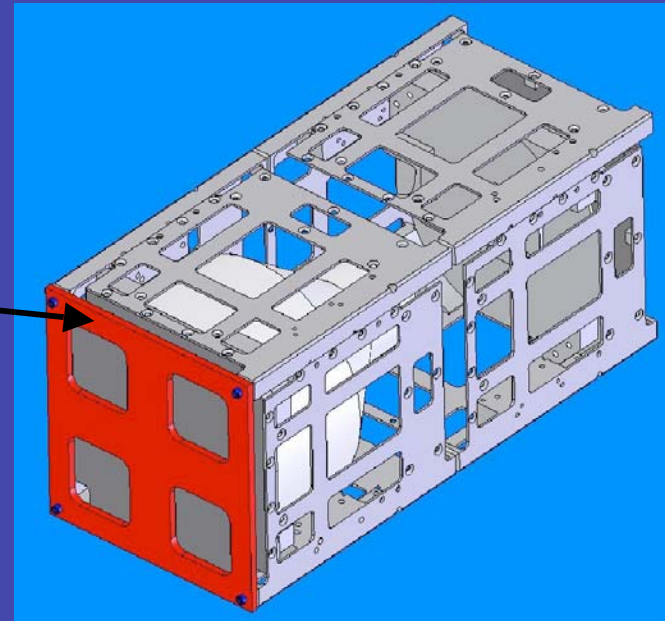
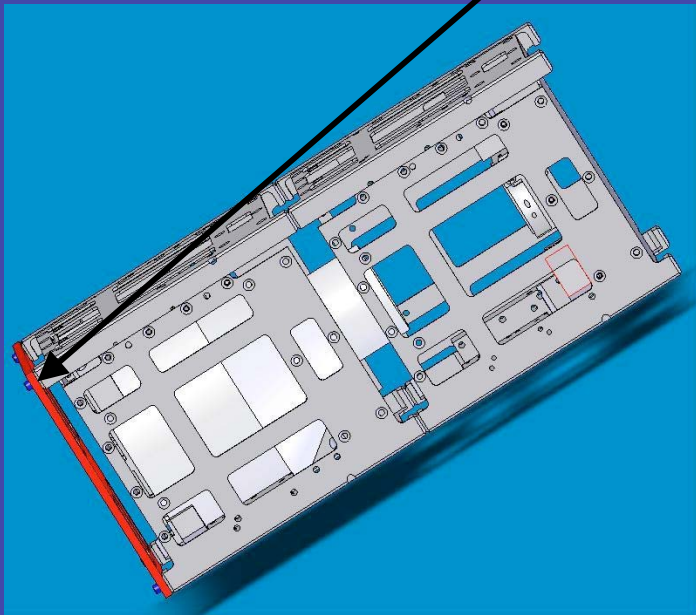

- Con: Possibly difficult to integrate
- Pro: Simple CubeSat Engineering

Access Port Cover

- The P-Pod electrical access door for the first CubeSat to deploy would be modified.
- Con: ~5-10cm shorter spring travel distance
- Pro: Simple CubeSat Engineering

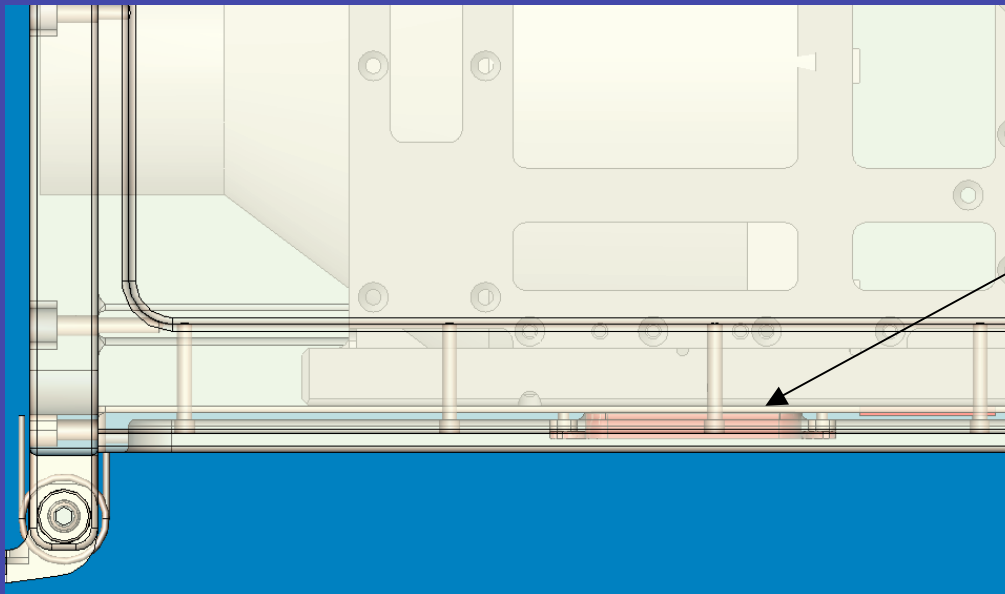
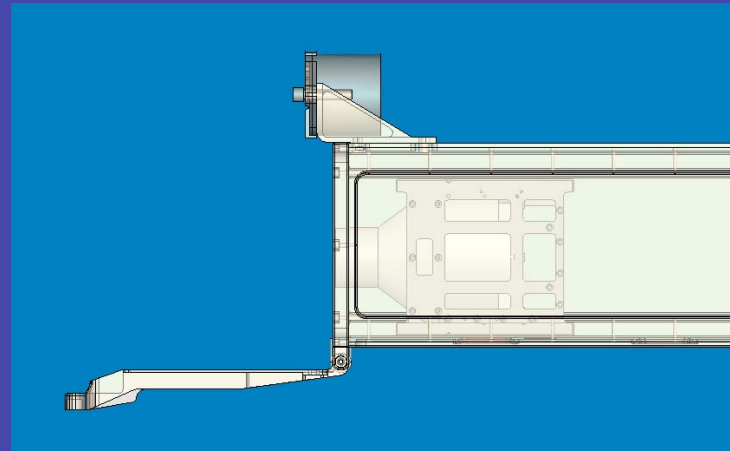

The modified door allows for in spec. CubeSats to exit but the last CubeSat will have an access door out of spec that prevents the satellite to exit.

Muzzle Fillets Interference

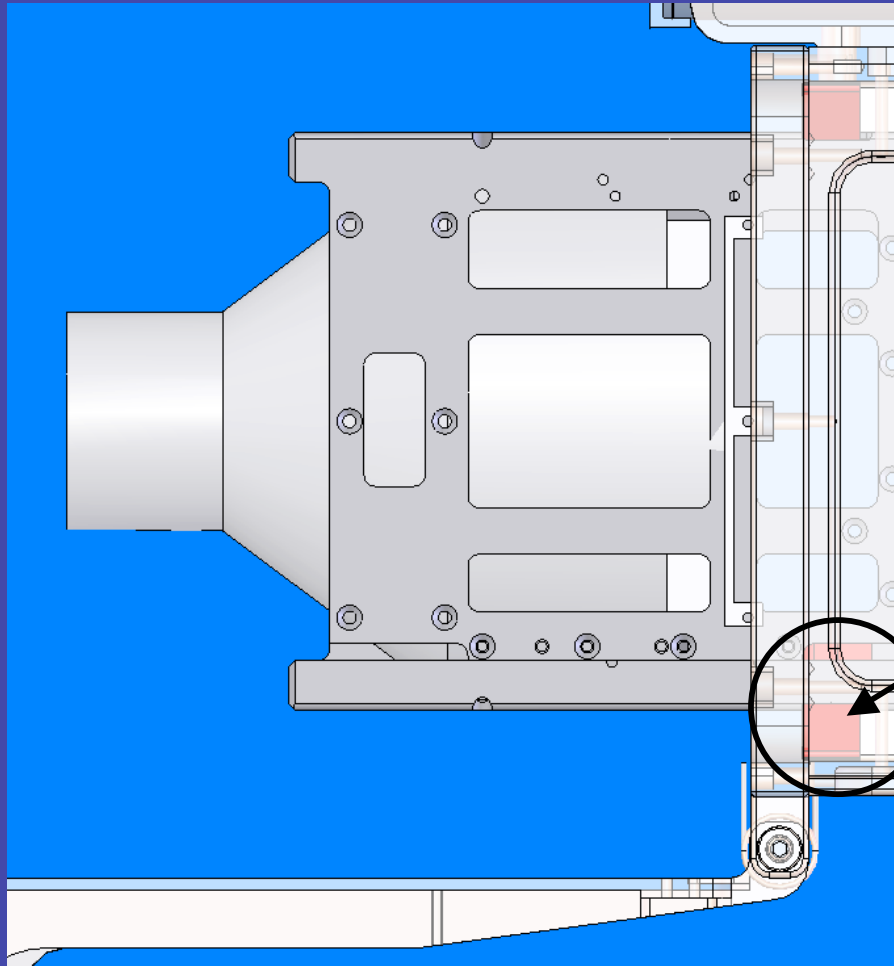

The doors in their extended state after the pull before flight pin has been pulled.

Muzzle Interference Details

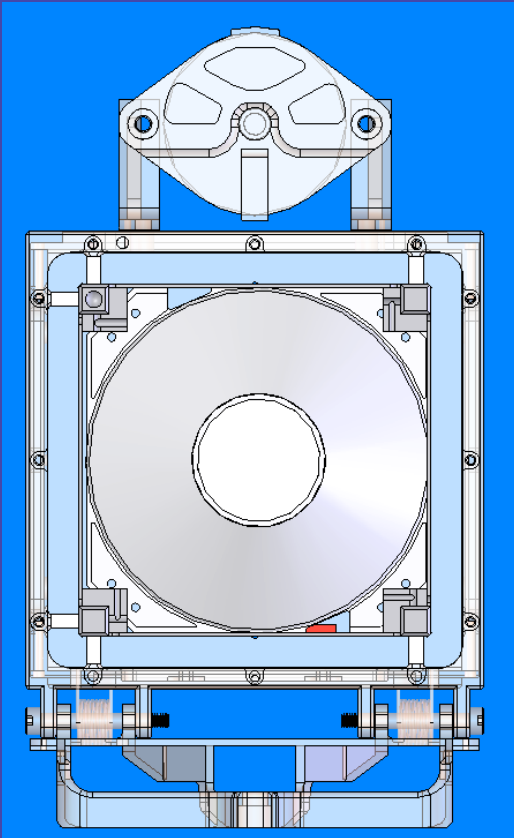

Doors Un-deployed

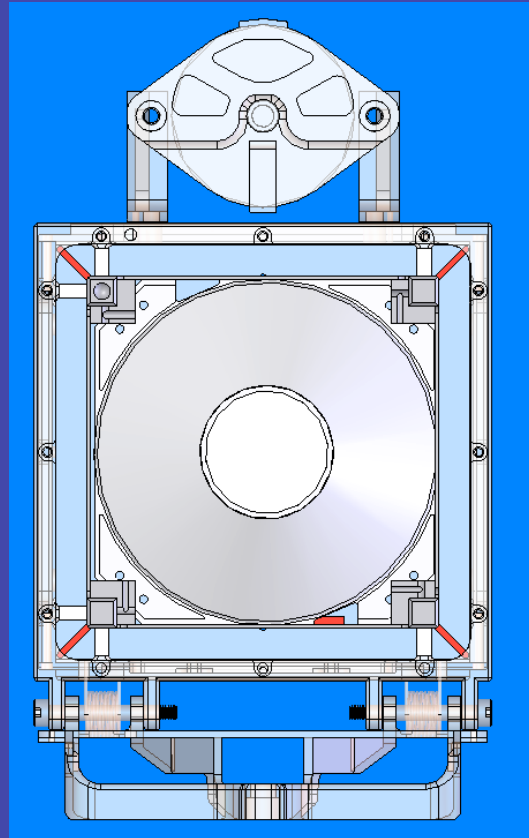

Doors Deployed

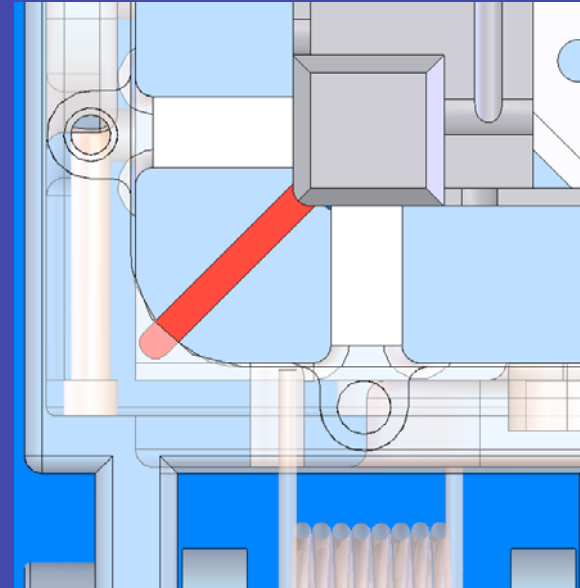

There is no contact on the sides of the P-Pod

- Con: More complex mechanism
- Pro: Complete Isolation

Tie On

Connection to the tether that will be bolted to the plunger plate.

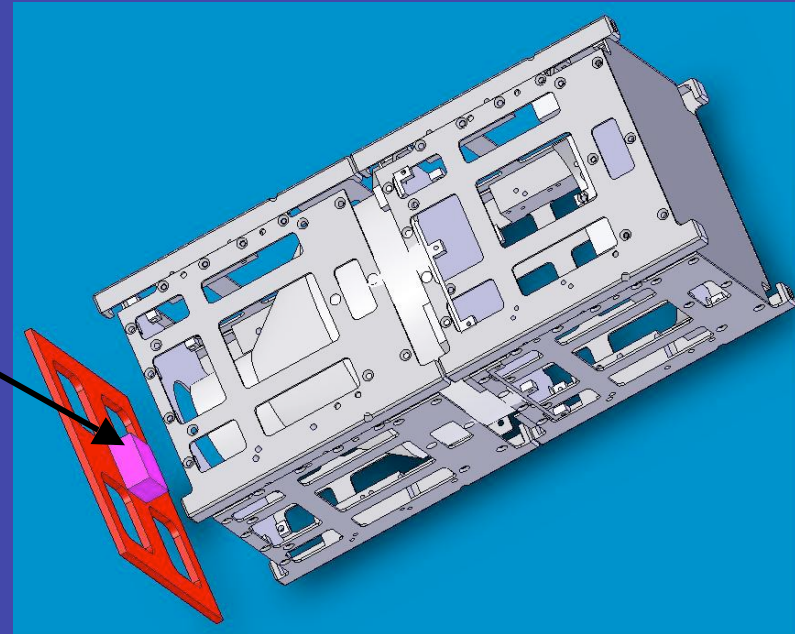
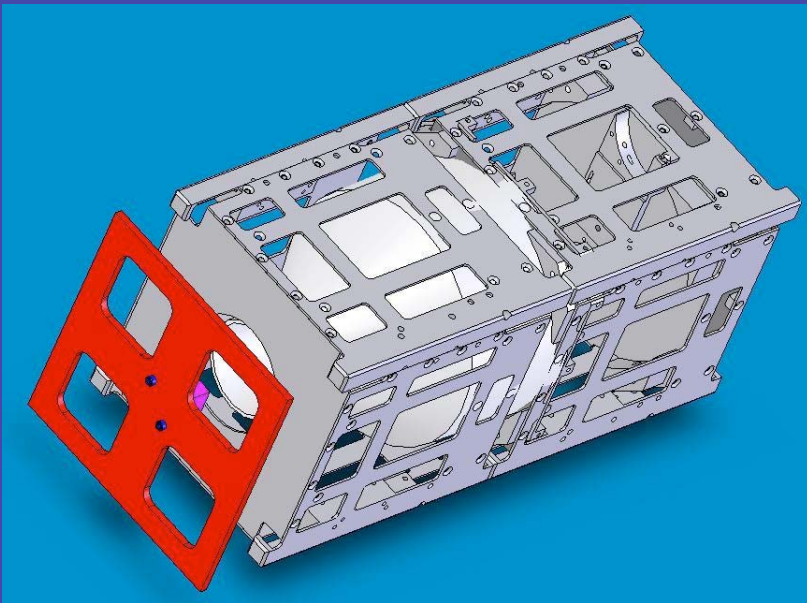

- Con: More complex mechanism
- Pro: Complete Isolation

Low Angle Operations

- Falcon 1 – Malaysiasat Launch (400km, 10°)
- Pro: More Passes
- Con: No USA Visible Passes

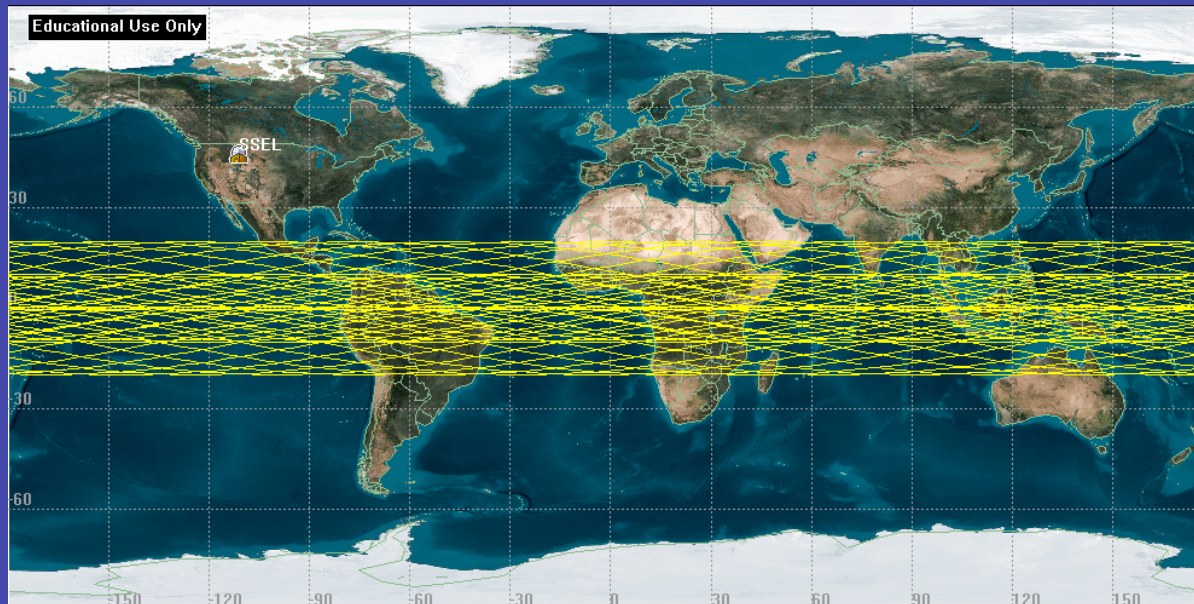

Low Angle Ops Options

- Location Operations (take station to swath)
 - Con: Need ~3 Months continuous ops
 - Pro: More Beaches
- Proxy Operations (Operate partner station remotely)
 - Cons: More engineering complexity, need close partner in nominal swath
 - Pro: Operate from comforts of home
- Network Operations (link through existing network)
 - Con: Stricter integration standards, no guarantees
 - Pro: Similar to Proxy, more open to community

Existing Network - APRS

Panama-To-Electra AER
Time (UTC): 17 Apr 2006 21:25:46.609
Azimuth (deg): 27.207
Elevation (deg): 72.296
Range (km): 419.301869

Educational Use Only

- Downlink = GPS + some telemetry
- Requirements
 - Equatorial hams
 - Standard APRS gateway within range
 - Appropriate coordination (network integration)

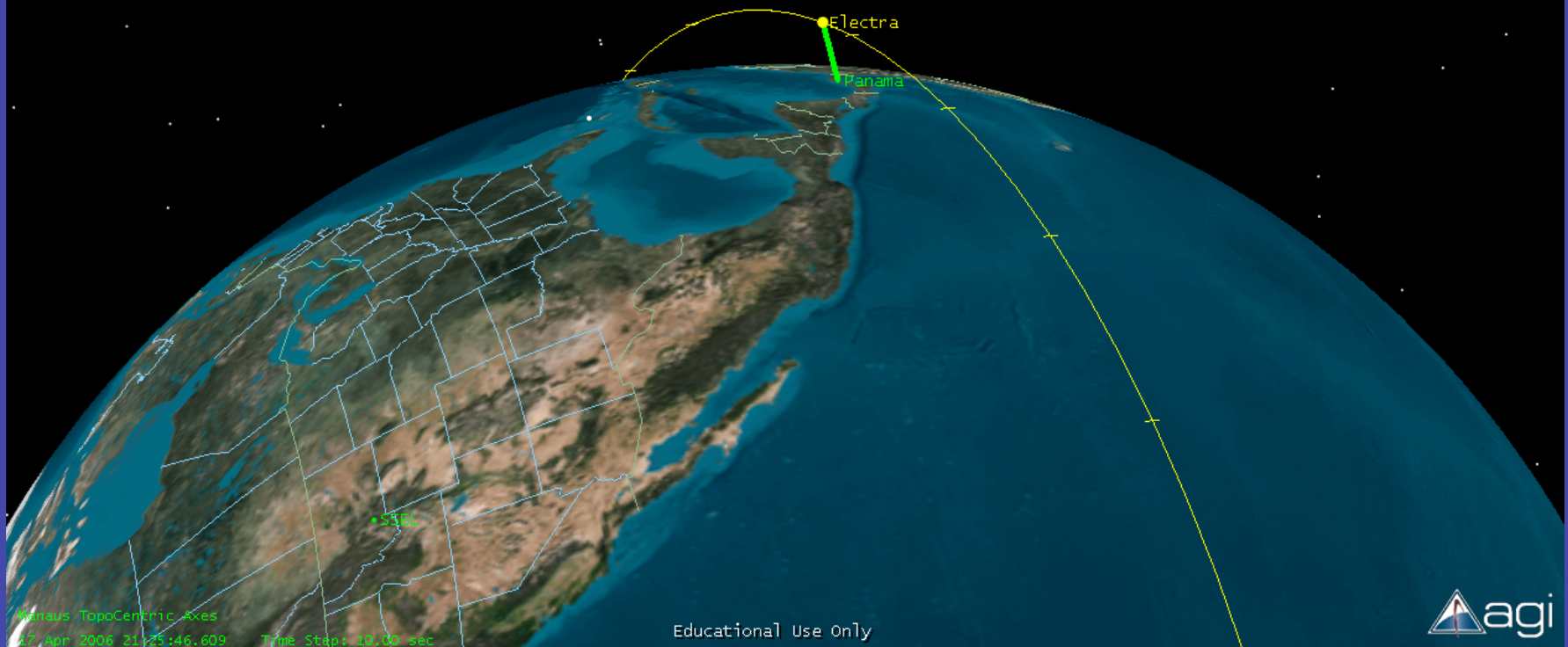

Conclusions

- Electra adaptations for PPOD flight
 - Tethered flight integration strategies
 - Many engineering options, all have integration challenges
- Specific to Malaysiasat launch
 - Short time-frame
 - APRS network possibilities?